

Synchronous Systems

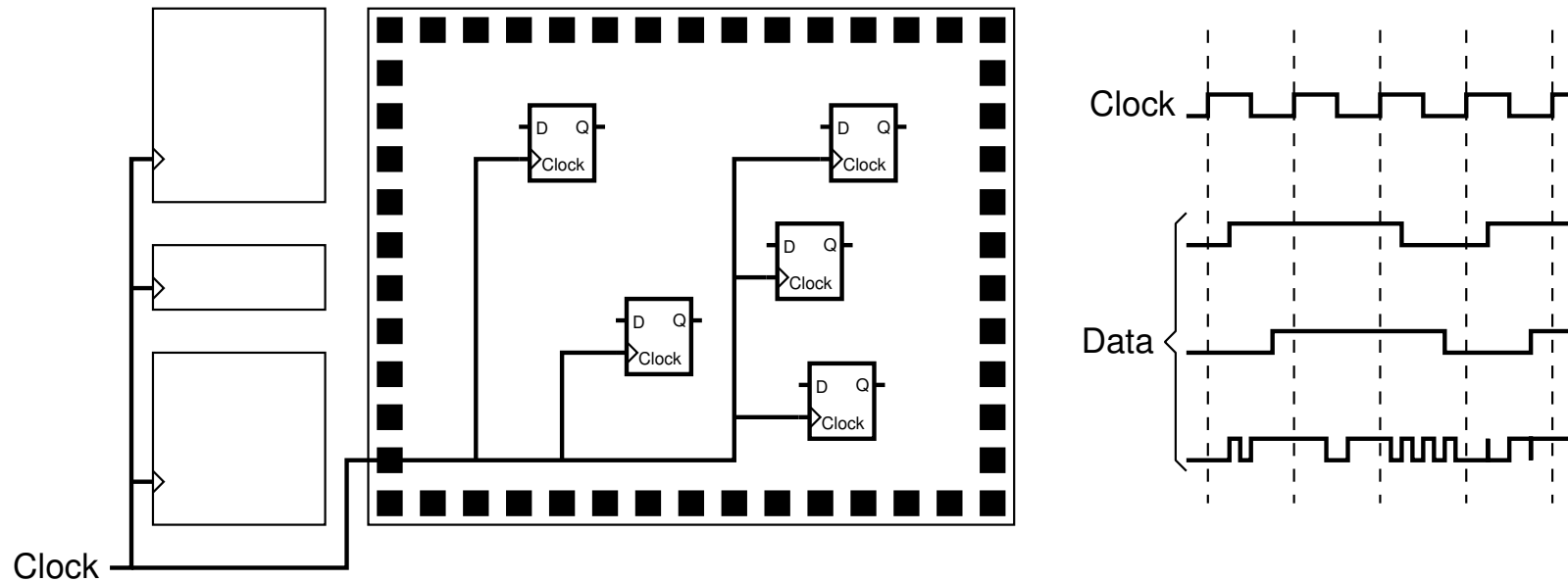

- All parts of the system share the same clock
- The data may change between active clock transitions but must be stable by the time the next active transition occurs¹.

¹for most systems the *active transition* is the rising edge of the clock

Synchronous Systems

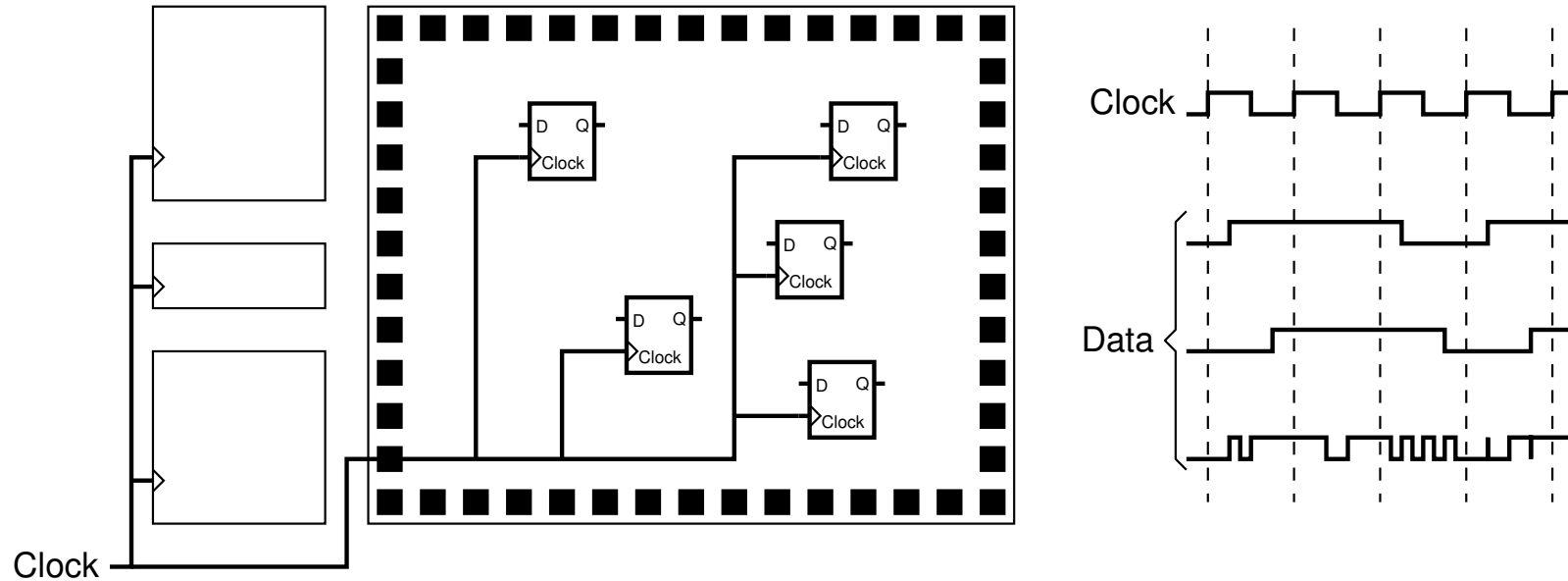

- All parts of the system share the same clock and the same clock edge sensitivity.
- The data may change between active clock transitions but must be stable by the time the next active transition occurs¹.

¹for most systems the *active transition* is the rising edge of the clock

Synchronous Systems

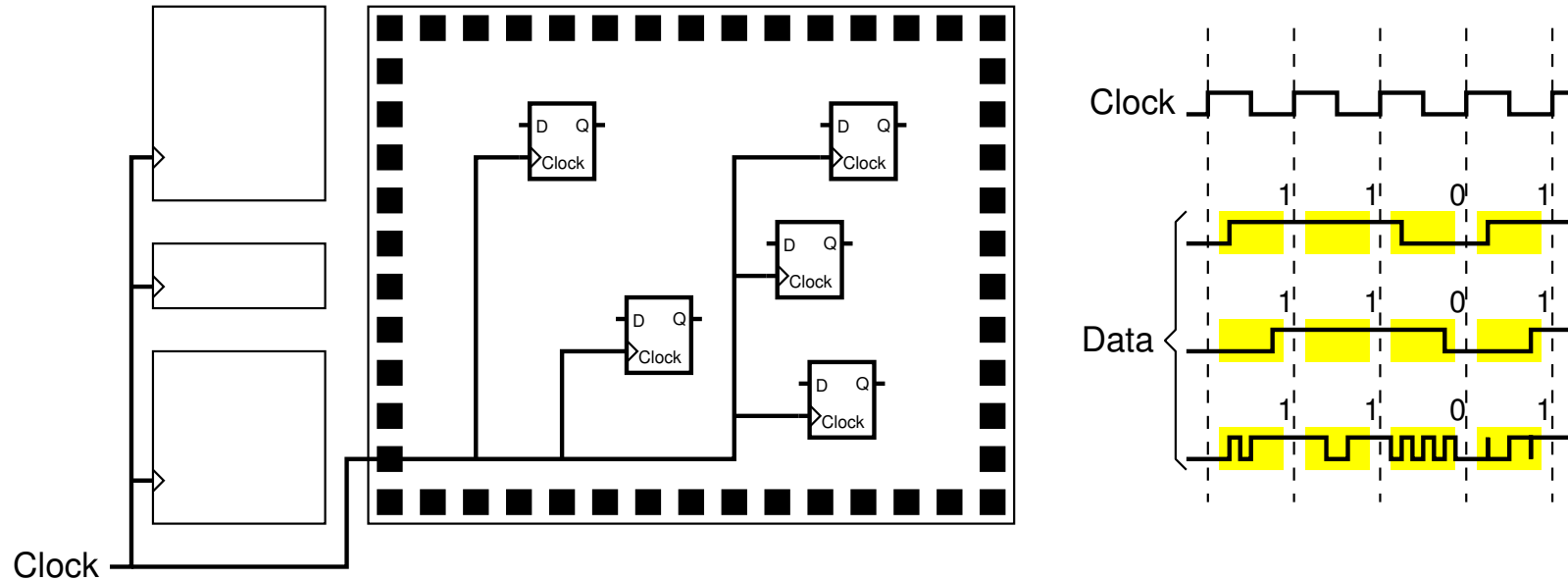

- All parts of the system share the same clock and the same clock edge sensitivity.
- The data may change between active clock transitions but must be stable by the time the next active transition occurs¹.

¹for most systems the *active transition* is the rising edge of the clock

Synchronous Systems - D-type Timing

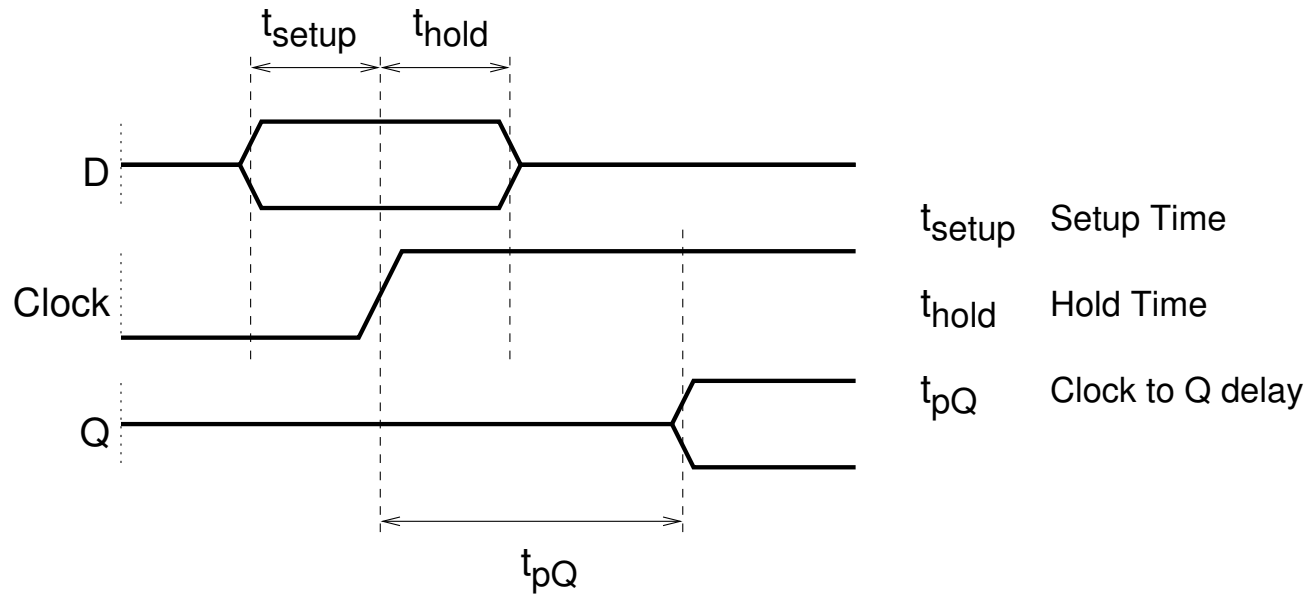

- Valid data should be present on D input for at least t_{setup} before the active clock edge and at least t_{hold} after the clock edge.
- The minimum D-type cycle time will be limited by the sum $t_{setup} + t_{pQ}$.

Synchronous Systems - Static Timing Analysis (Ideal Clock)

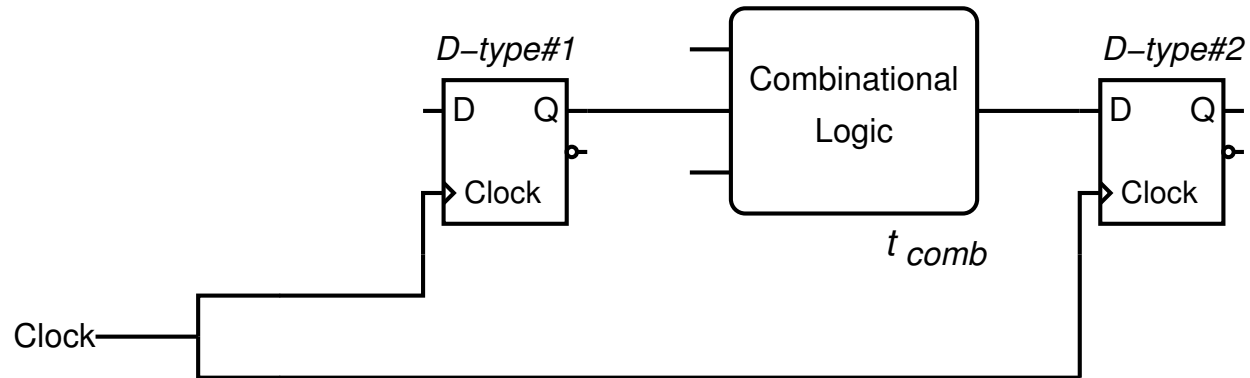

- To avoid a setup violation:

$$ClockPeriod > t_{pQ} + t_{comb} + t_{setup}$$

- To avoid a hold violation:

$$t_{pQ} + t_{comb} > t_{hold}$$

Synchronous Systems

Static Timing Analysis

- Predicts the timing of a circuit without simulation²
- Analysis of gate network based on:
 - Propagation delays
 - Set-up and hold times for storage elements
 - Constraints such as desired operating frequency and the timing of inputs and outputs

Note that the examples given here are simplified in that they reduce the propagation delay through a gate to a single number - in reality there are predictable and unpredictable variations in gate delays which must be accounted for by static timing analysis tools.

²timing simulations for large digital systems are slow and will usually not catch all edge and corner cases

Synchronous Systems - Static Timing Analysis (Ideal Clock)

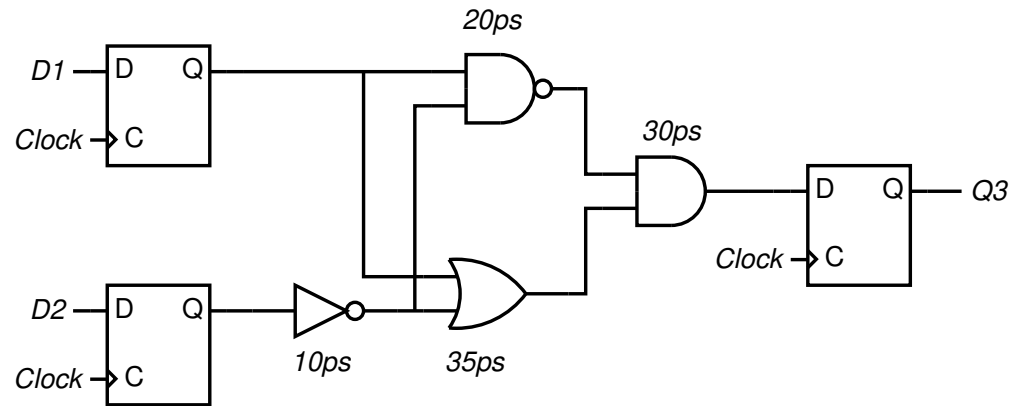

- To avoid a setup violation:

$$\text{ClockPeriod} > t_{pQ} + t_{comb-max} + t_{setup}$$

- To avoid a hold violation:

$$t_{pQ} + t_{comb-min} > t_{hold}$$

Synchronous Systems - Static Timing Analysis (Ideal Clock)

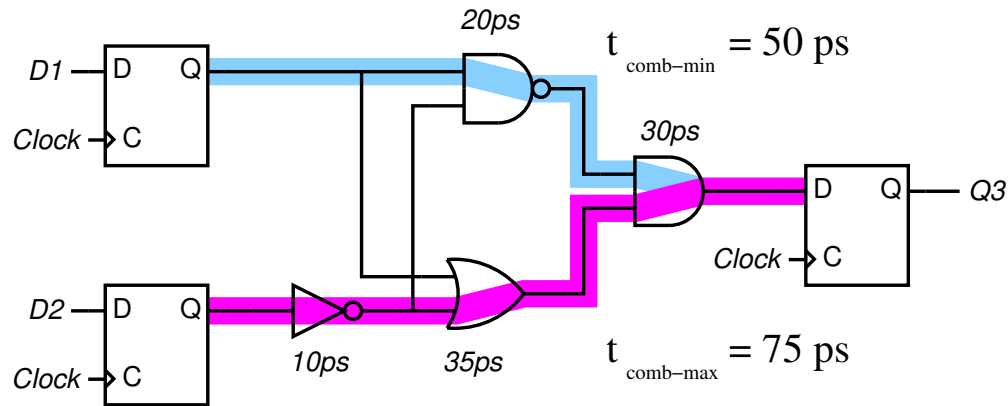

- To avoid a setup violation:

$$ClockPeriod > t_{pQ} + t_{comb-max} + t_{setup}$$

- To avoid a hold violation:

$$t_{pQ} + t_{comb-min} > t_{hold}$$

Synchronous Systems - Static Timing Analysis (Ideal Clock)

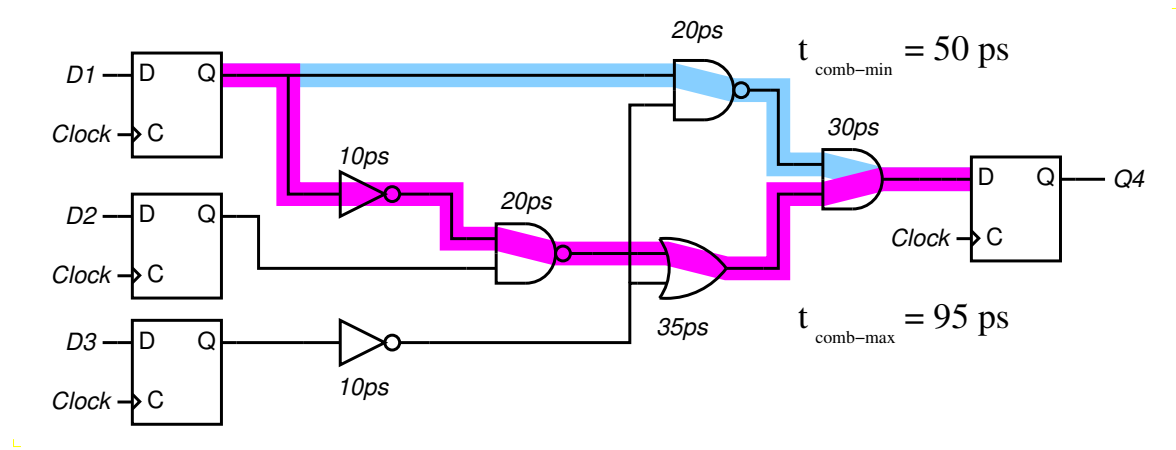

- To avoid a setup violation:

$$\text{ClockPeriod} > t_{pQ} + t_{comb-max} + t_{setup}$$

- To avoid a hold violation:

$$t_{pQ} + t_{comb-min} > t_{hold}$$

Synchronous Systems - Static Timing Analysis (Ideal Clock)

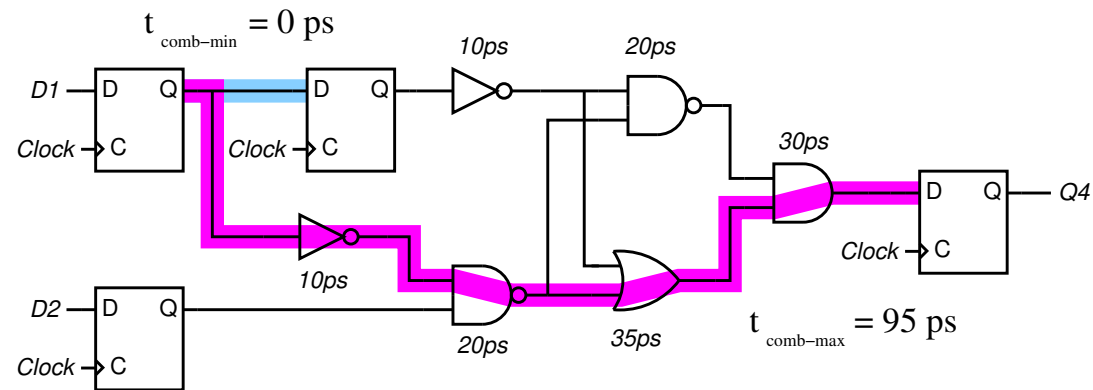

- To avoid a setup violation:

$$ClockPeriod > t_{pQ} + t_{comb-max} + t_{setup}$$

- To avoid a hold violation:

$$t_{pQ} + t_{comb-min} > t_{hold}$$

Synchronous Systems - Static Timing Analysis (Ideal Clock)

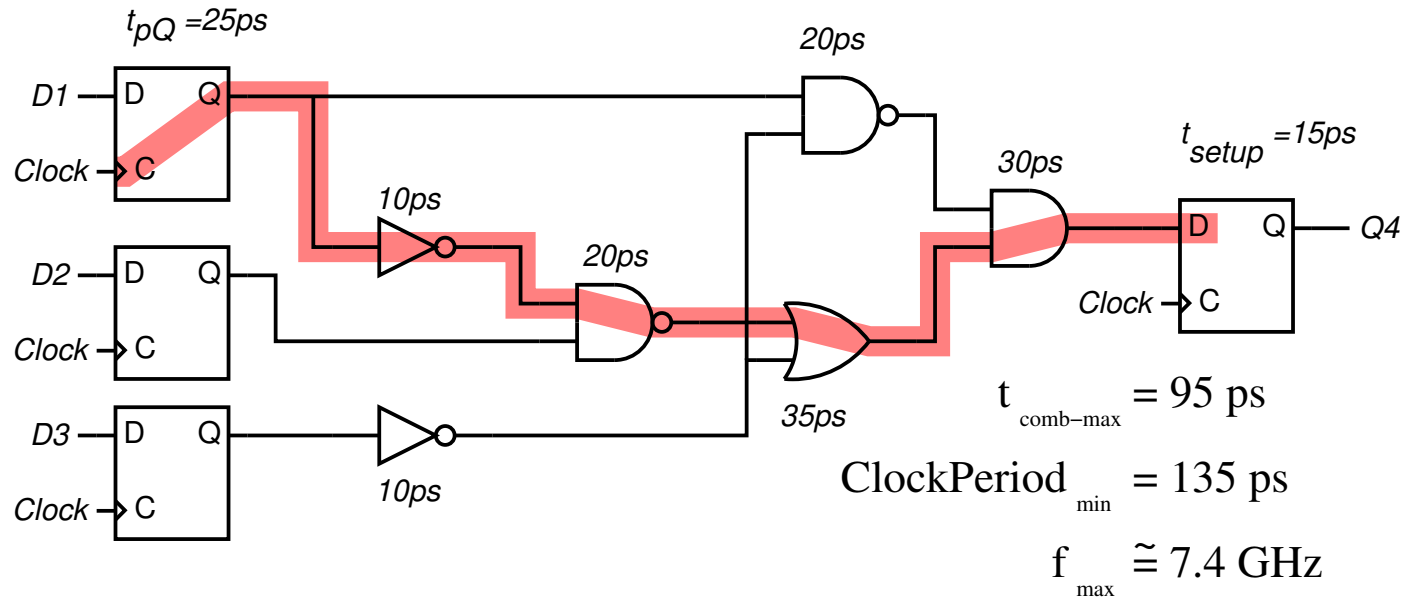

- Critical path analysis allows us to determine the maximum feasible clock frequency:

$$ClockPeriod > t_{pQ} + t_{comb-max} + t_{setup}$$

$$f_{max} = \frac{1}{t_{pQ} + t_{comb-max} + t_{setup}}$$

Synchronous Systems - Static Timing Analysis (Ideal Clock)

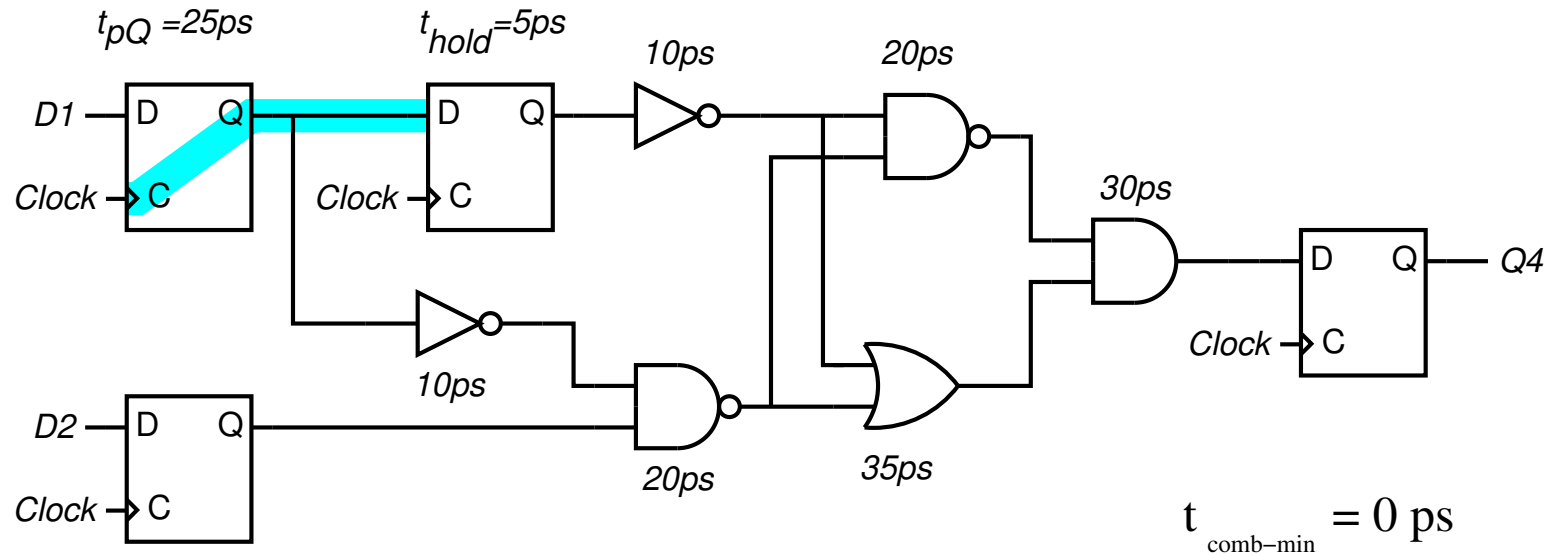

$$t_{pQ} + t_{comb-min} > t_{hold}$$

If we have an ideal clock and $t_{pQ} > t_{hold}$ we won't see hold violations even with if $t_{comb-min} = 0$.

Synchronous Systems - Clock Skew

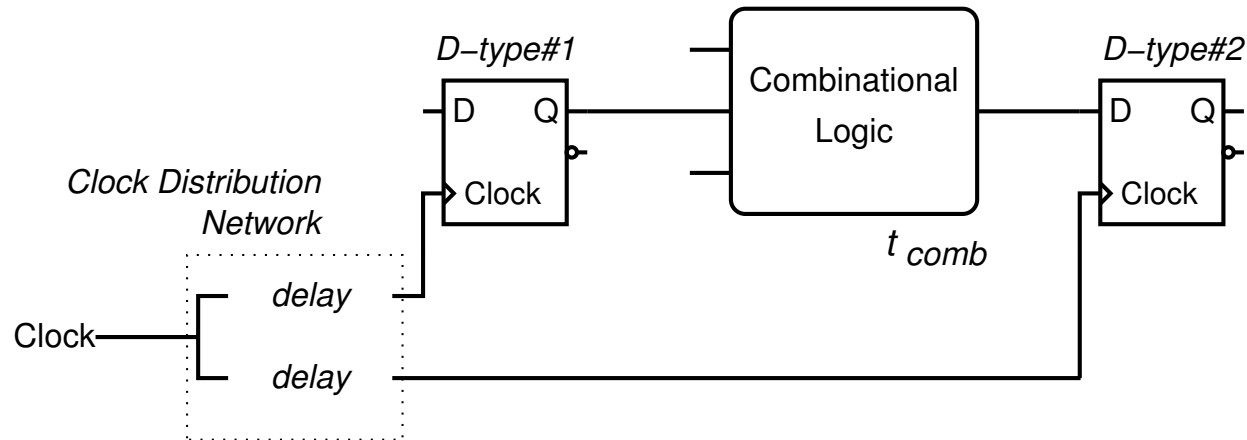

- Clock Distribution

The process of distributing clocks from a central source gives rise to delays.

Clock skew is the difference between the arrival times of the clock at different points in the circuit.

- Clock Skew may cause unexpected timing violations

Hold: if *D-type #1* clocks first, *D* input of *D-type #2* may change too early³

Setup: if *D-type #1* clocks second, *D* input of *D-type #2* may change too late

³most likely where combinational logic is minimal or absent

Synchronous Systems - Clock Skew

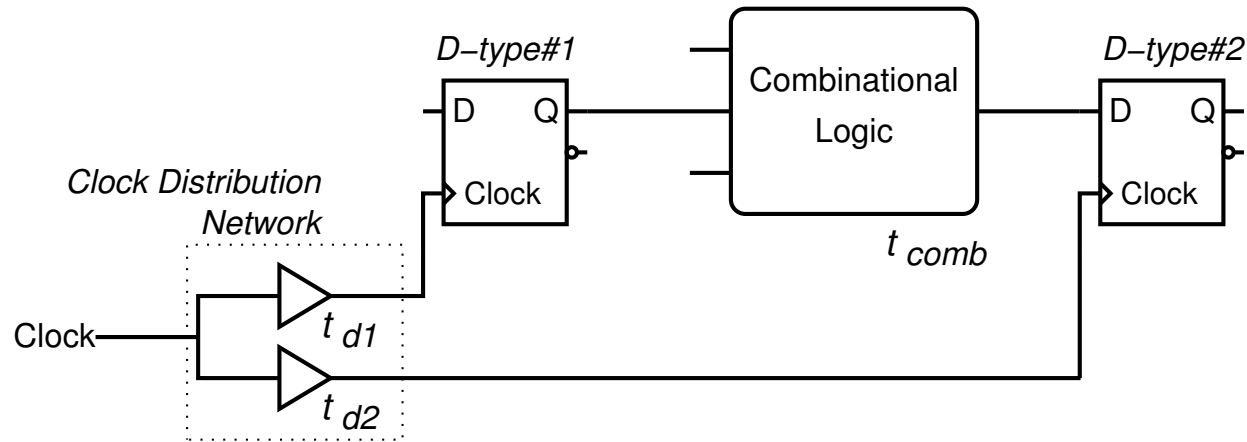

- Clock Distribution

The process of distributing clocks from a central source gives rise to delays.

Clock skew is the difference between the arrival times of the clock at different points in the circuit.

- Clock Skew may cause unexpected timing violations

Hold: if *D-type #1* clocks first, *D* input of *D-type #2* may change too early³

Setup: if *D-type #1* clocks second, *D* input of *D-type #2* may change too late

³most likely where combinational logic is minimal or absent

Synchronous Systems - Static Timing Analysis (inc. clock skew)

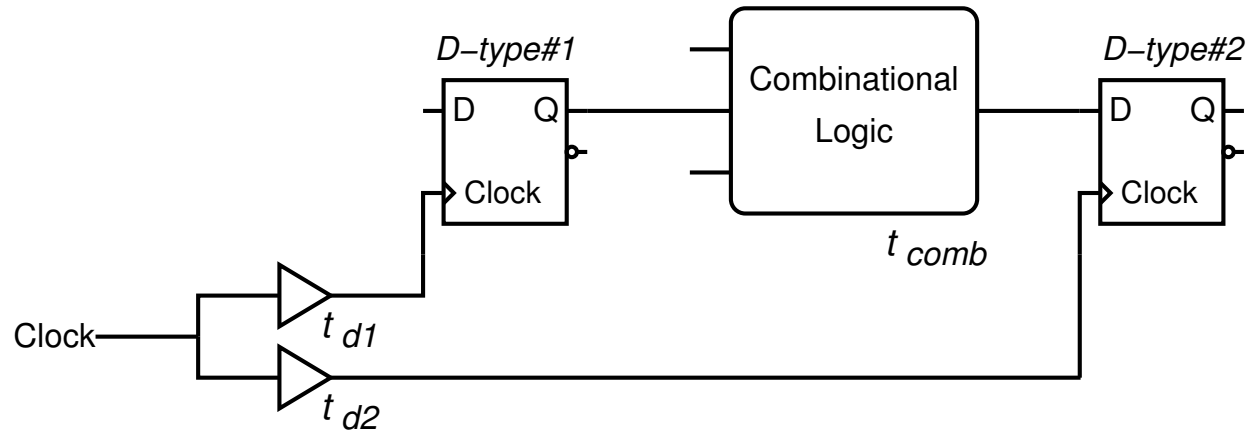

- To avoid a setup violation:

$$\text{ClockPeriod} + t_{d2} > t_{pQ} + t_{comb} + t_{setup} + t_{d1}$$

- To avoid a hold violation:

$$t_{pQ} + t_{comb} + t_{d1} > t_{hold} + t_{d2}$$

Synchronous Systems - Static Timing Analysis (inc. clock skew)

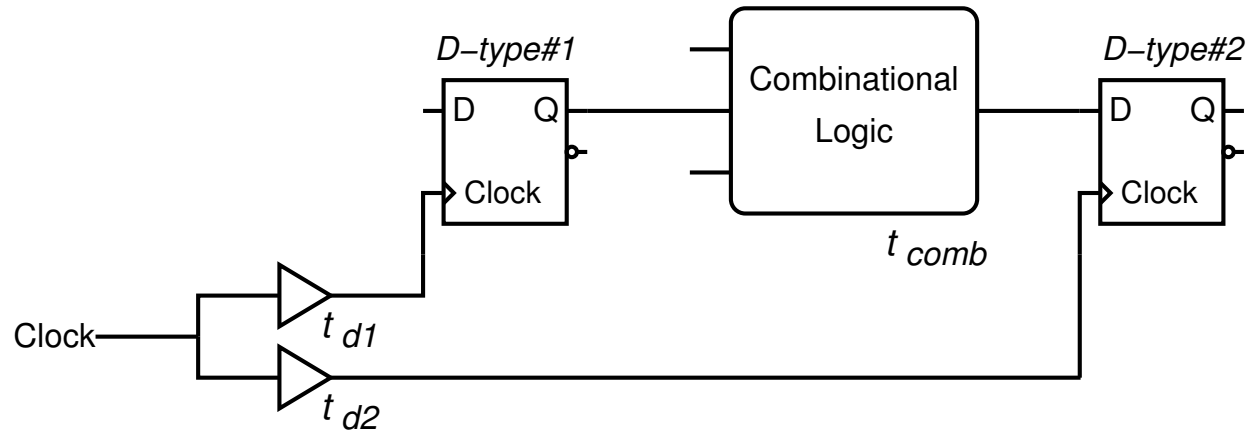

- To avoid a setup violation:

$$ClockPeriod > t_{pQ} + t_{comb} + t_{setup} + (t_{d1} - t_{d2})$$

- To avoid a hold violation:

$$t_{pQ} + t_{comb} > t_{hold} + (t_{d2} - t_{d1})$$

Synchronous Systems - Static Timing Analysis (inc. clock skew)

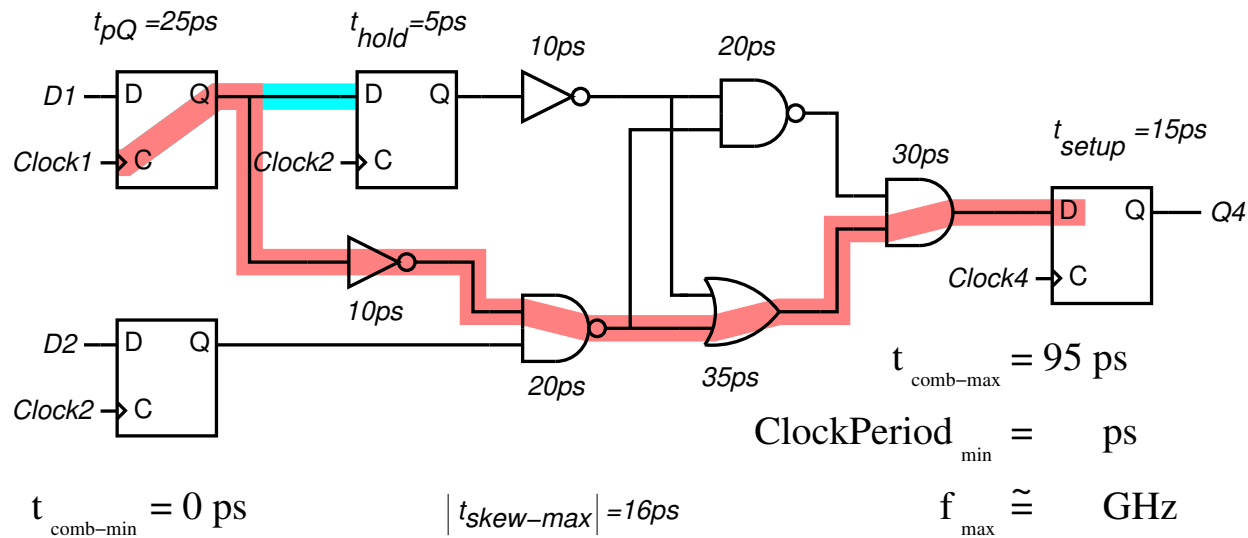

- What is the maximum operating frequency of the circuit if the clock skew is no more than 16ps?

$$ClockPeriod > t_{pQ} + t_{comb} + t_{setup} + t_{skew}$$

- What is the maximum clock skew that can be tolerated before we have a hold violation?

$$t_{pQ} + t_{comb} > t_{hold} + t_{skew}$$

Synchronous Systems - Static Timing Analysis (inc. clock skew)

Critical Path

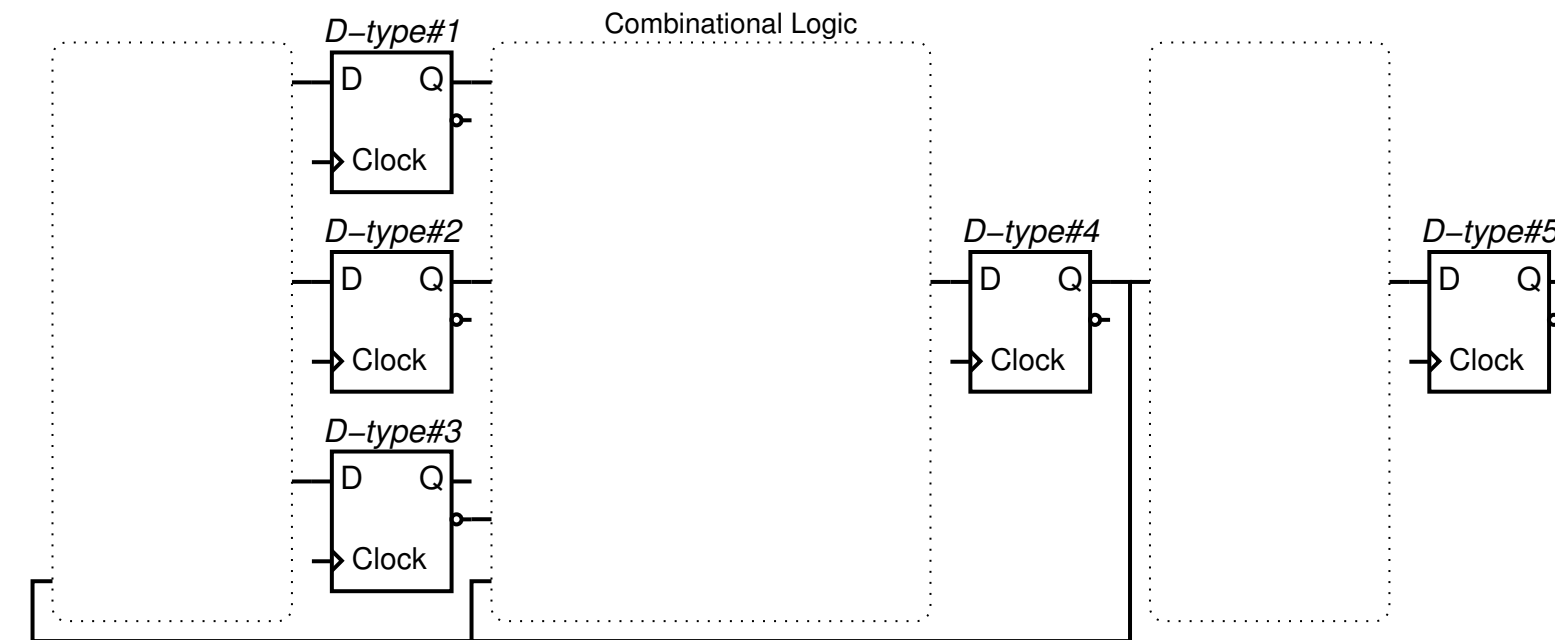

- To avoid a setup violation:

$$ClockPeriod > t_{pQ} + t_{critical_path} + t_{setup} + t_{skew}$$

Synchronous Systems - Static Timing Analysis (inc. clock skew)

Critical Path

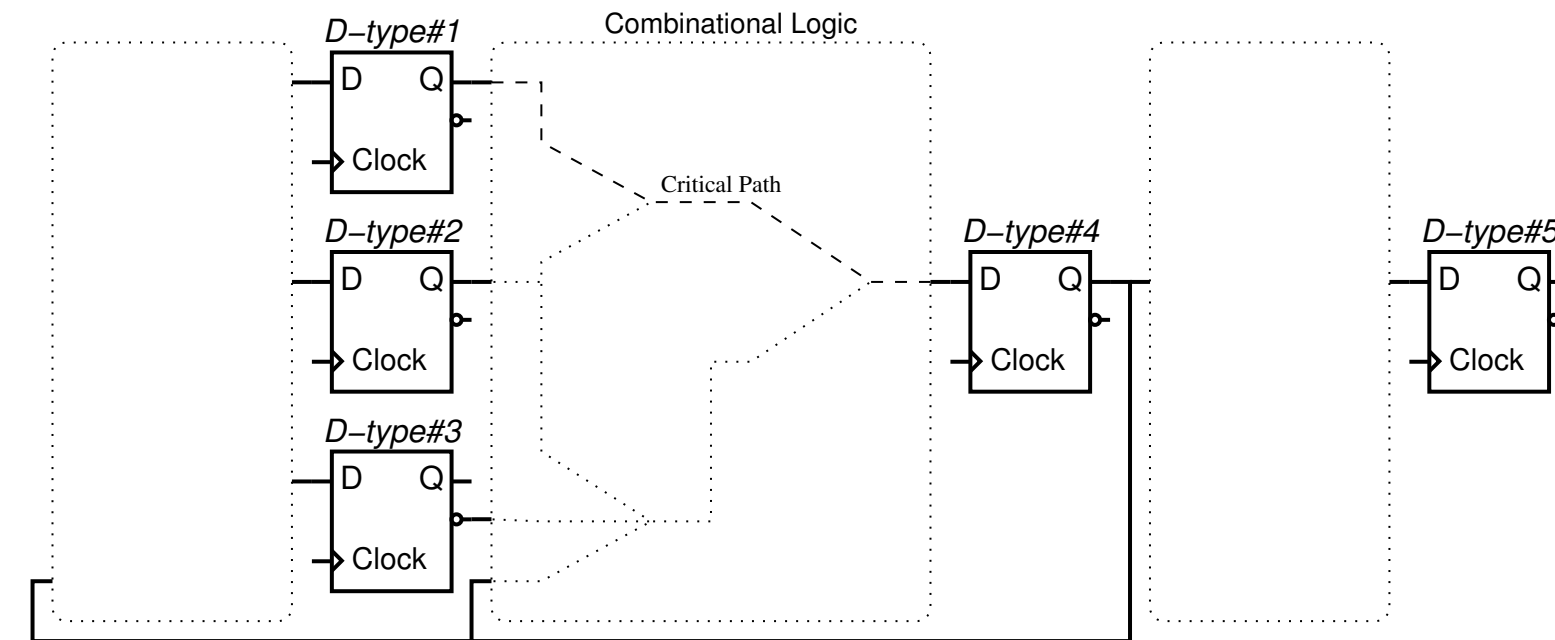

- To avoid a setup violation:

$$\text{ClockPeriod} > t_{pQ} + t_{critical_path} + t_{setup} + (t_{d1} - t_{d4})$$

Synchronous Systems - Static Timing Analysis (inc. clock skew)

Critical Path

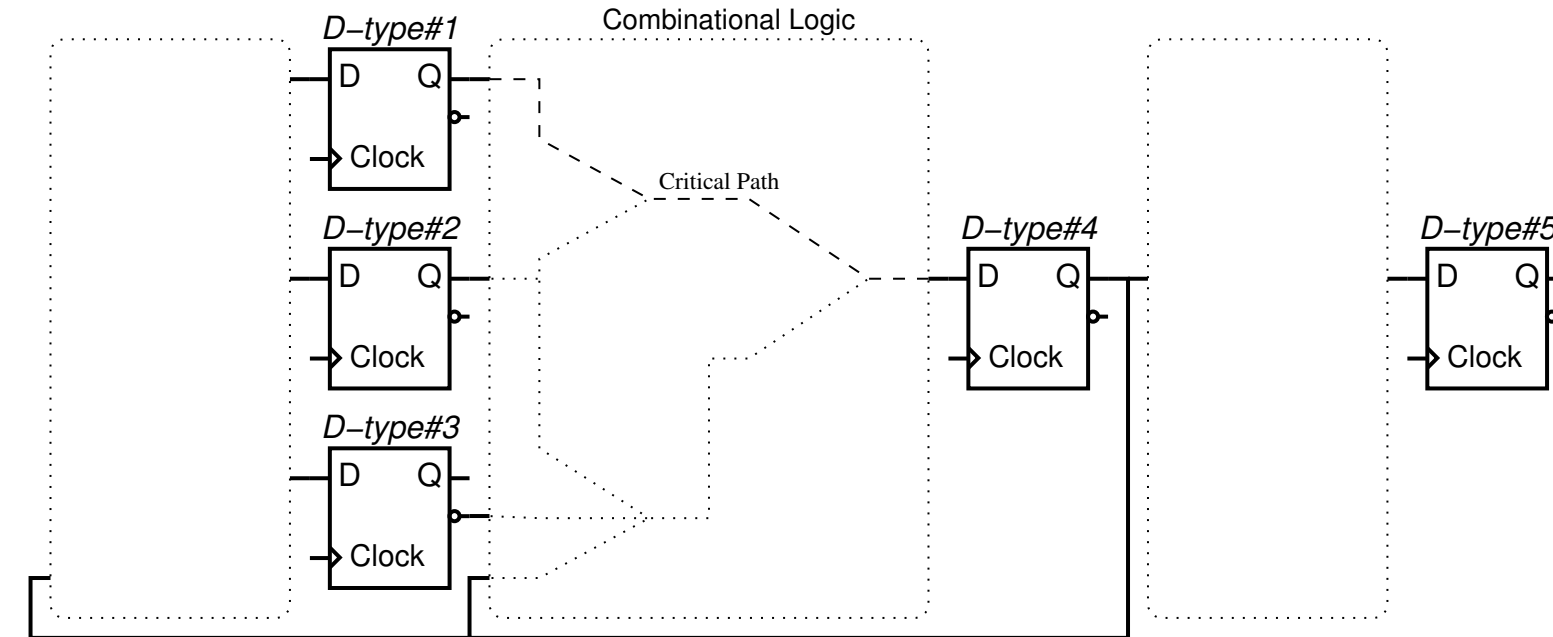

$$\text{ClockPeriod} > t_{pQ} + t_{critical_path} + t_{setup} + (t_{d1} - t_{d4})$$

- If we can control the skew (e.g. by increasing t_{d4}), we can ease the timing constraint.⁴

⁴this may result in the critical path moving to another part of the circuit

Synchronous Systems - Static Timing Analysis (inc. clock skew)

Critical Path

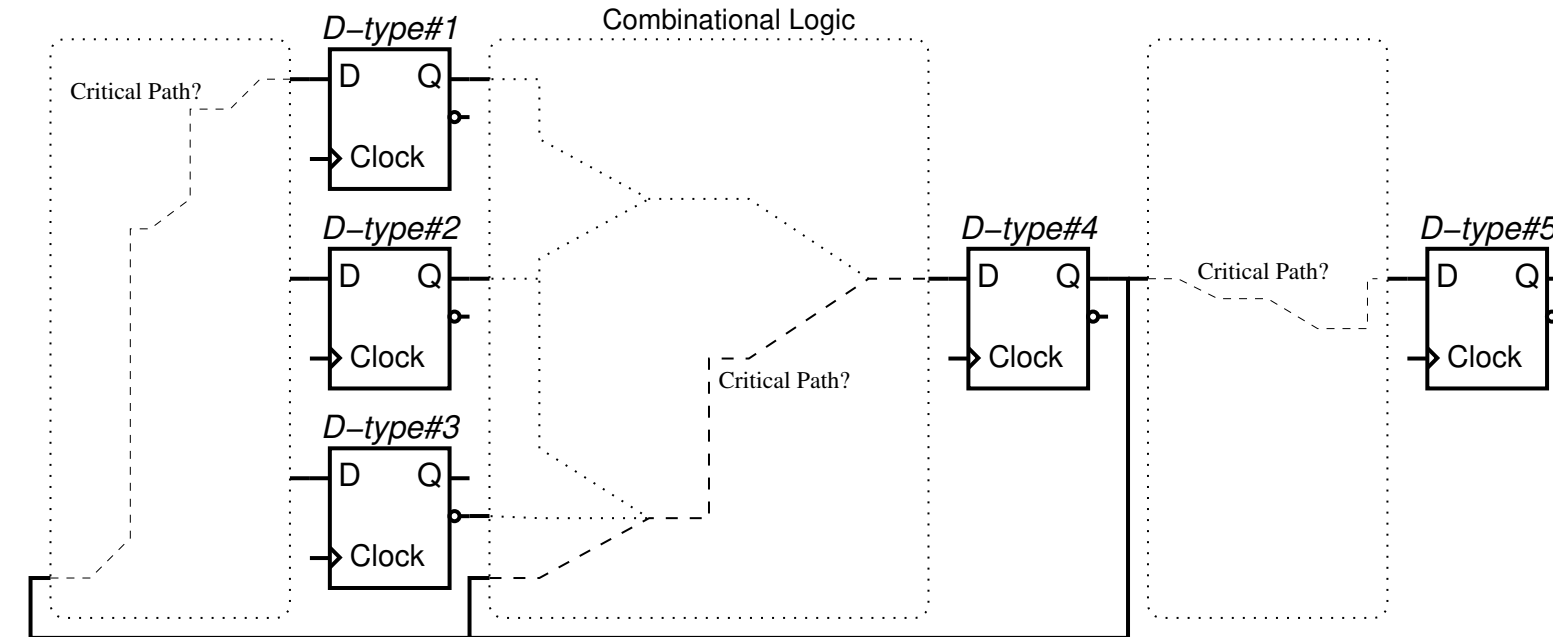

$$ClockPeriod > t_{pQ} + t_{critical_path} + t_{setup} + (t_{d_{launch}} - t_{d_{capture}})$$

- If we can control the skew (e.g. by increasing t_{d4}), we can ease the timing constraint.⁴

⁴this may result in the critical path moving to another part of the circuit

Synchronous Systems - Static Timing Analysis (inc. clock skew)

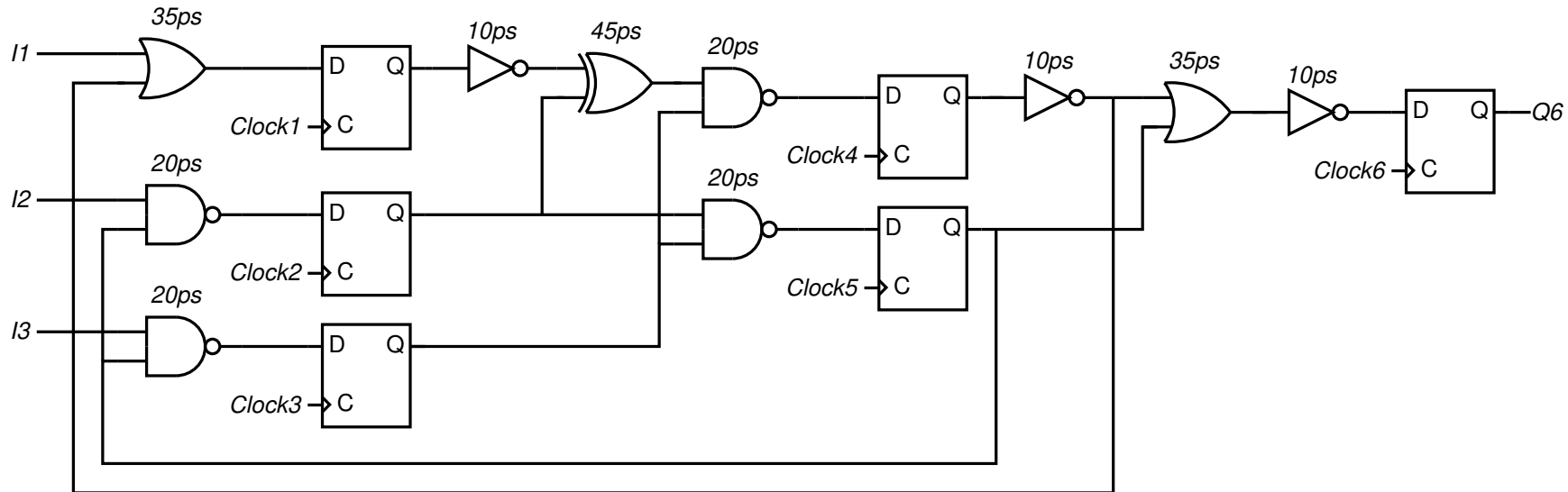

- Calculate f_{max} in the presence of intentional clock skew.

Synchronous Systems - Static Timing Analysis (inc. clock skew)

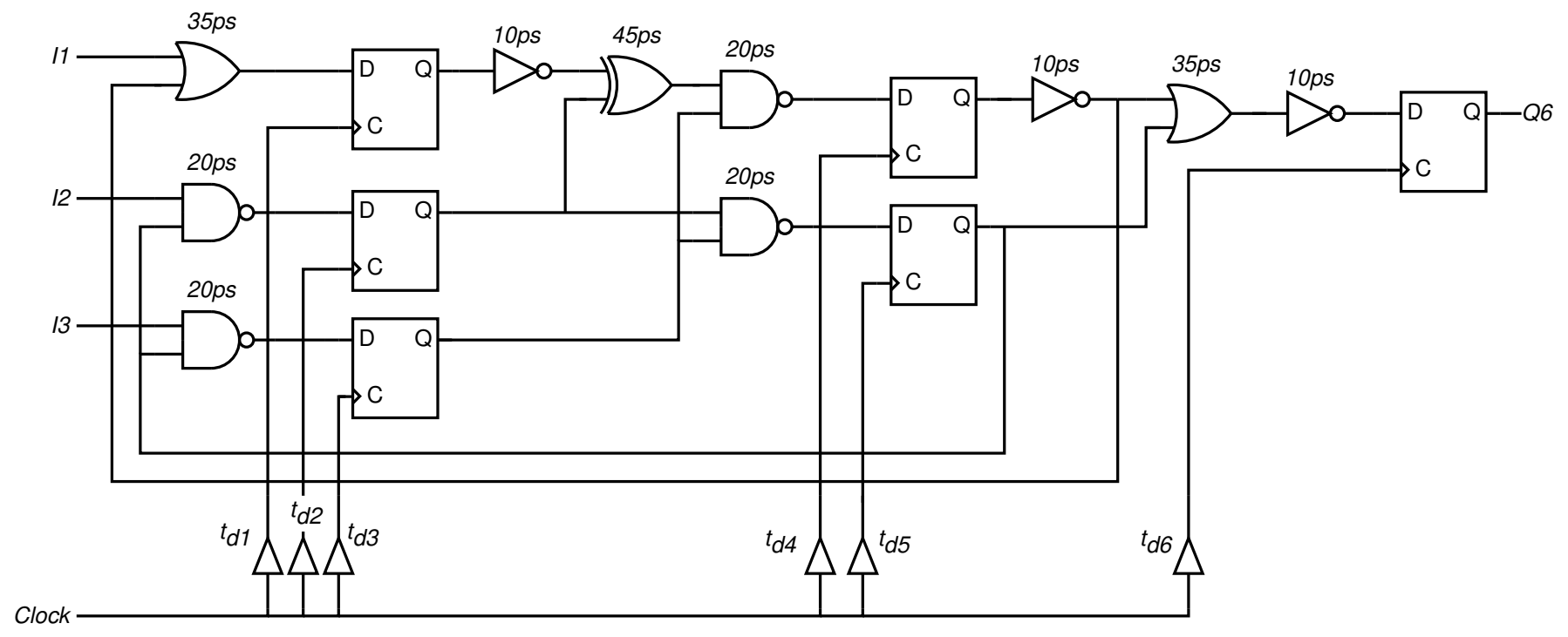

- Calculate f_{max} in the presence of intentional clock skew.
- Suggest suitable values for $t_{d1}, t_{d2}, t_{d3}, t_{d4}, t_{d5}, t_{d6}$

Synchronous Systems - Static Timing Analysis (inc. clock skew)

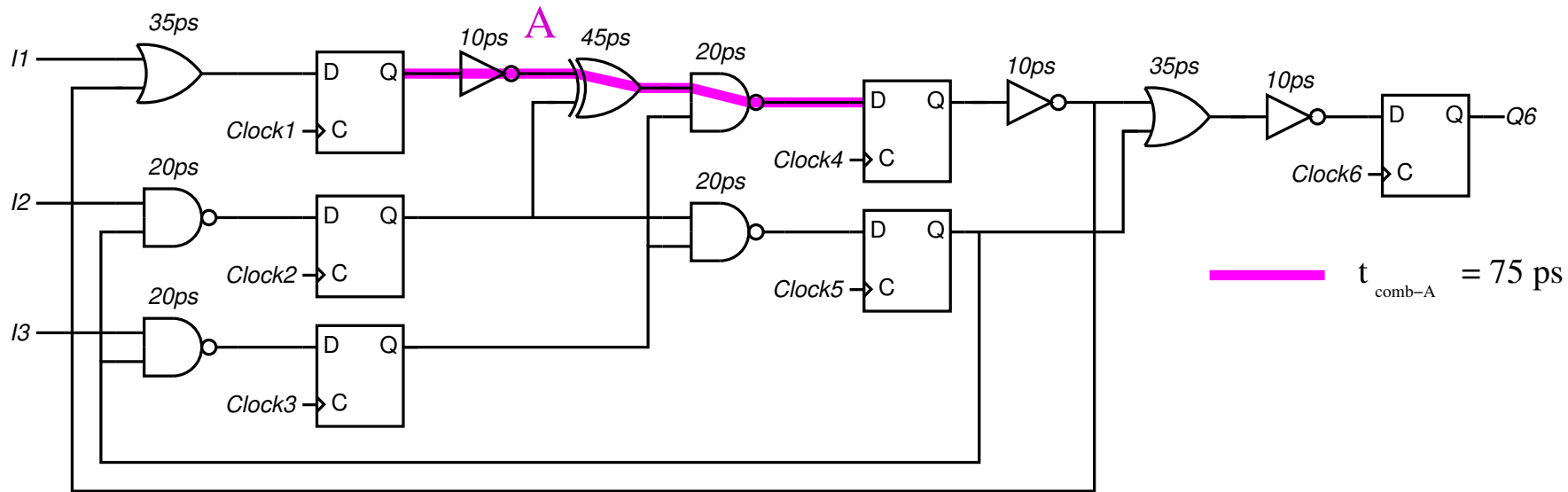

- Calculate f_{max} in the presence of intentional clock skew.
- Suggest suitable values for $t_{d1}, t_{d2}, t_{d3}, t_{d4}, t_{d5}, t_{d6}$

⇒ Identify longest combinational paths

Synchronous Systems - Static Timing Analysis (inc. clock skew)

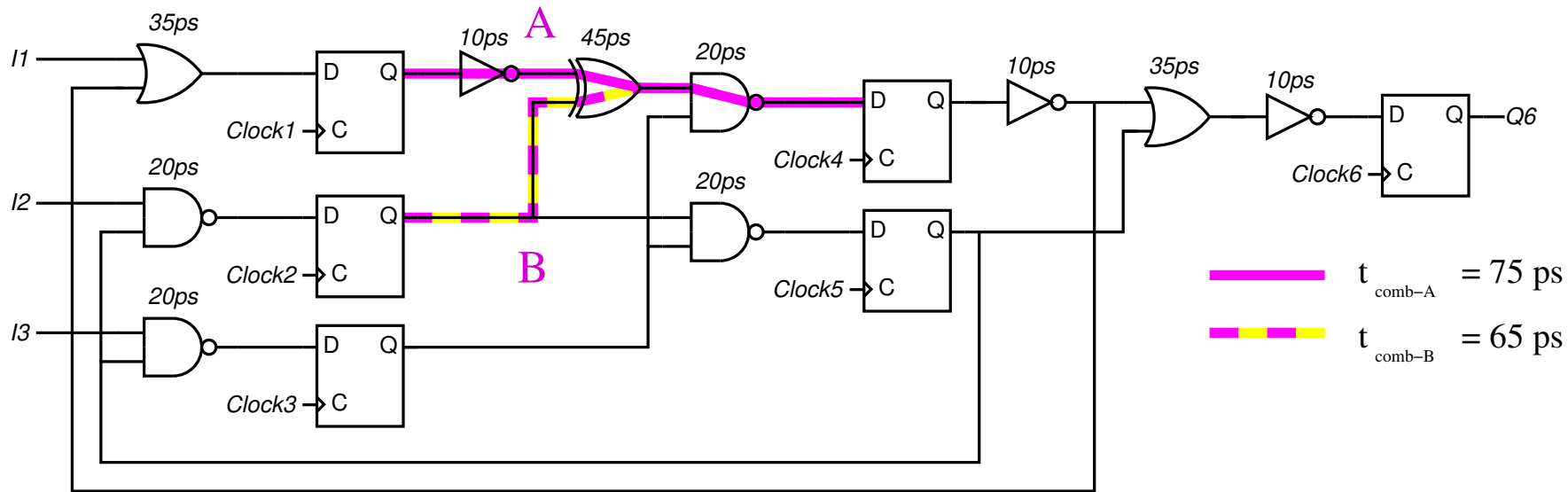

- Calculate f_{max} in the presence of intentional clock skew.
- Suggest suitable values for $t_{d1}, t_{d2}, t_{d3}, t_{d4}, t_{d5}, t_{d6}$

⇒ Identify longest combinational paths

Synchronous Systems - Static Timing Analysis (inc. clock skew)

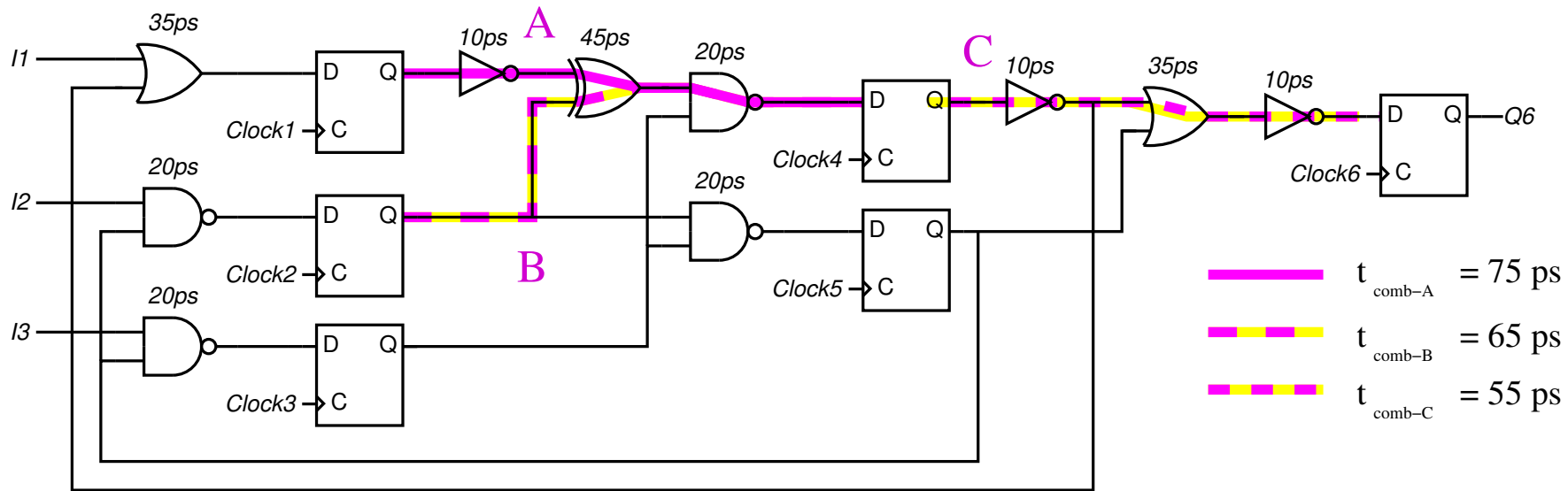

- Calculate f_{max} in the presence of intentional clock skew.
- Suggest suitable values for $t_{d1}, t_{d2}, t_{d3}, t_{d4}, t_{d5}, t_{d6}$

⇒ Identify longest combinational paths

Synchronous Systems - Static Timing Analysis (inc. clock skew)

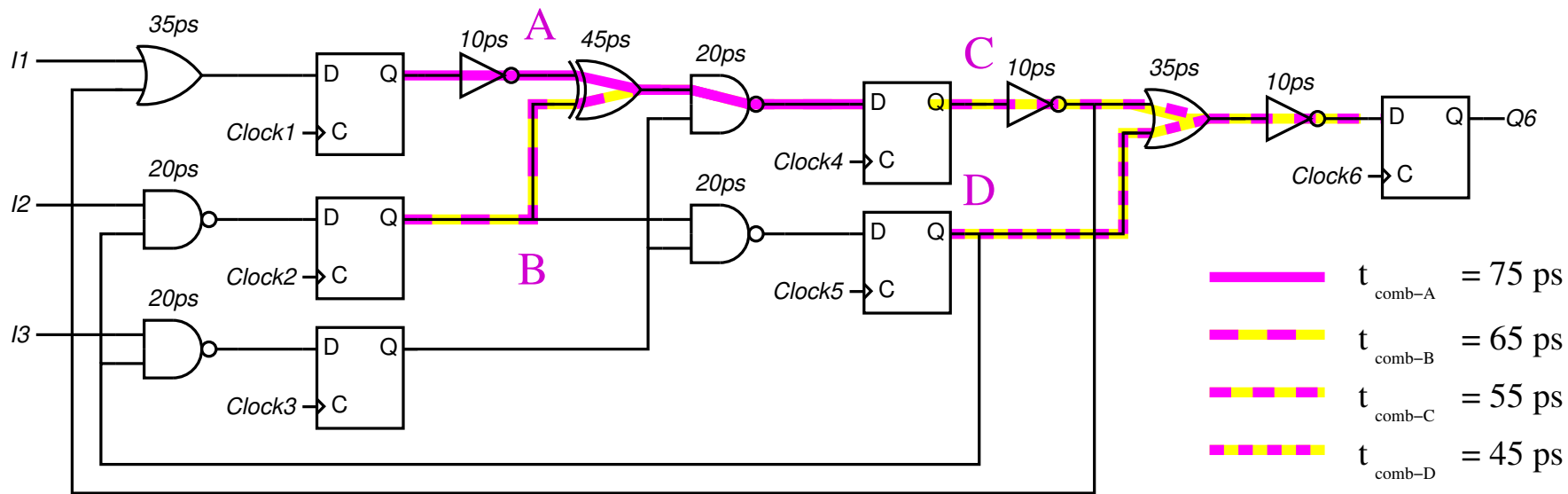

- Calculate f_{max} in the presence of intentional clock skew.
- Suggest suitable values for $t_{d1}, t_{d2}, t_{d3}, t_{d4}, t_{d5}, t_{d6}$

⇒ Identify longest combinational paths

Synchronous Systems - Static Timing Analysis (inc. clock skew)

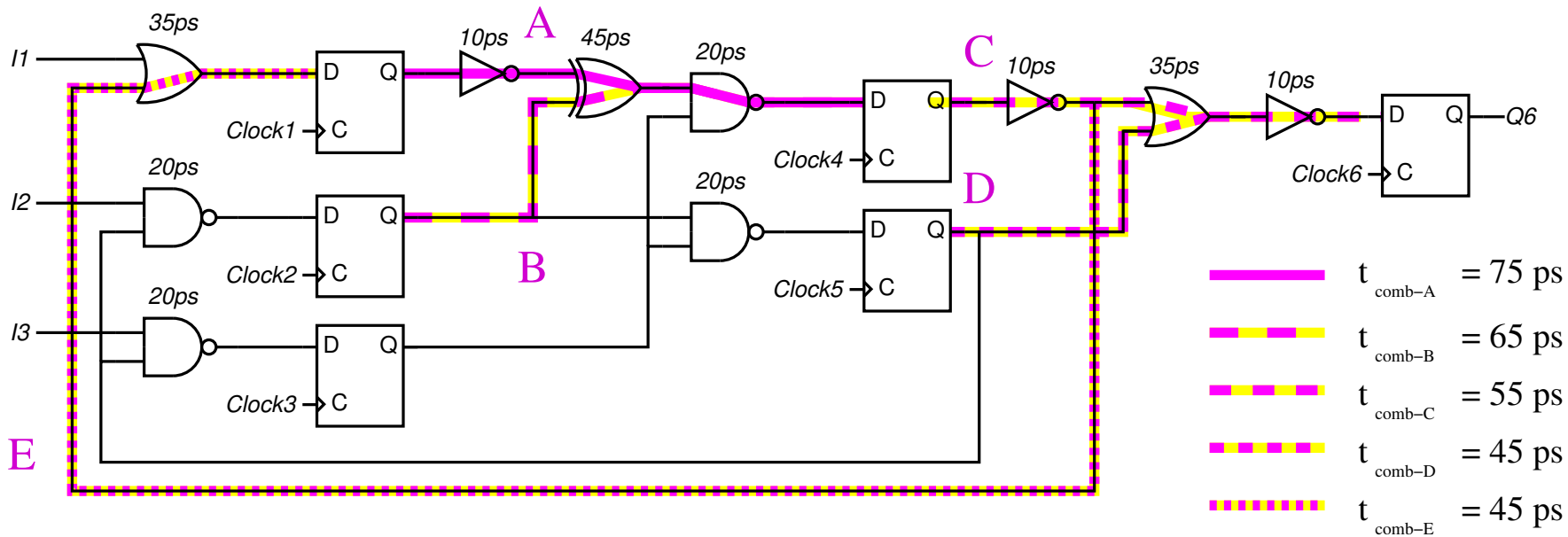

- Calculate f_{max} in the presence of intentional clock skew.
- Suggest suitable values for $t_{d1}, t_{d2}, t_{d3}, t_{d4}, t_{d5}, t_{d6}$

⇒ Identify longest combinational paths

Synchronous Systems - Static Timing Analysis (inc. clock skew)

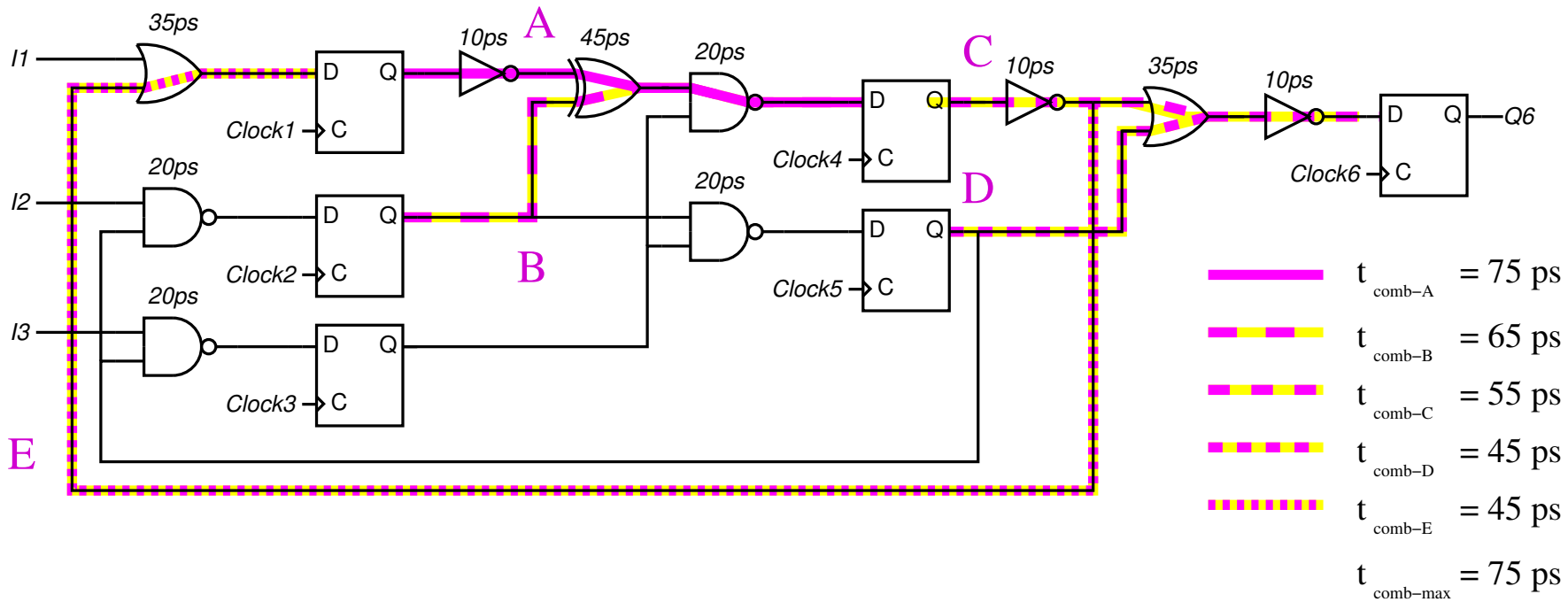

- Calculate f_{max} in the presence of intentional clock skew.
- Suggest suitable values for $t_{d1}, t_{d2}, t_{d3}, t_{d4}, t_{d5}, t_{d6}$

⇒ Identify longest combinational paths

Synchronous Systems - Static Timing Analysis (inc. clock skew)

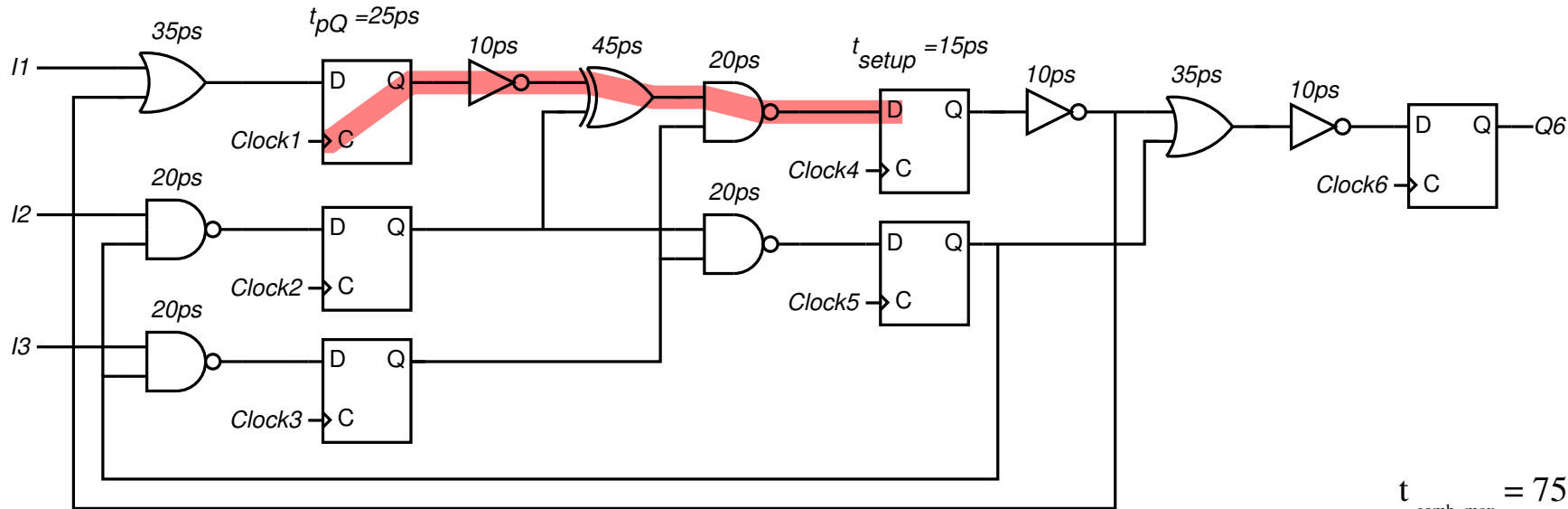

$$t_{comb-max} = 75 \text{ ps}$$

$$\text{ClockPeriod}_{min} = 115 \text{ ps}$$

$$f_{max} \cong 8.7 \text{ GHz}$$

$$\text{ClockPeriod} > t_{pQ} + t_{comb-max} + t_{setup} + (t_{d1} - t_{d4})$$

$$f_{max} = \frac{1}{t_{pQ} + t_{comb-max} + t_{setup} + (t_{d1} - t_{d4})}$$

Synchronous Systems - Static Timing Analysis (inc. clock skew)

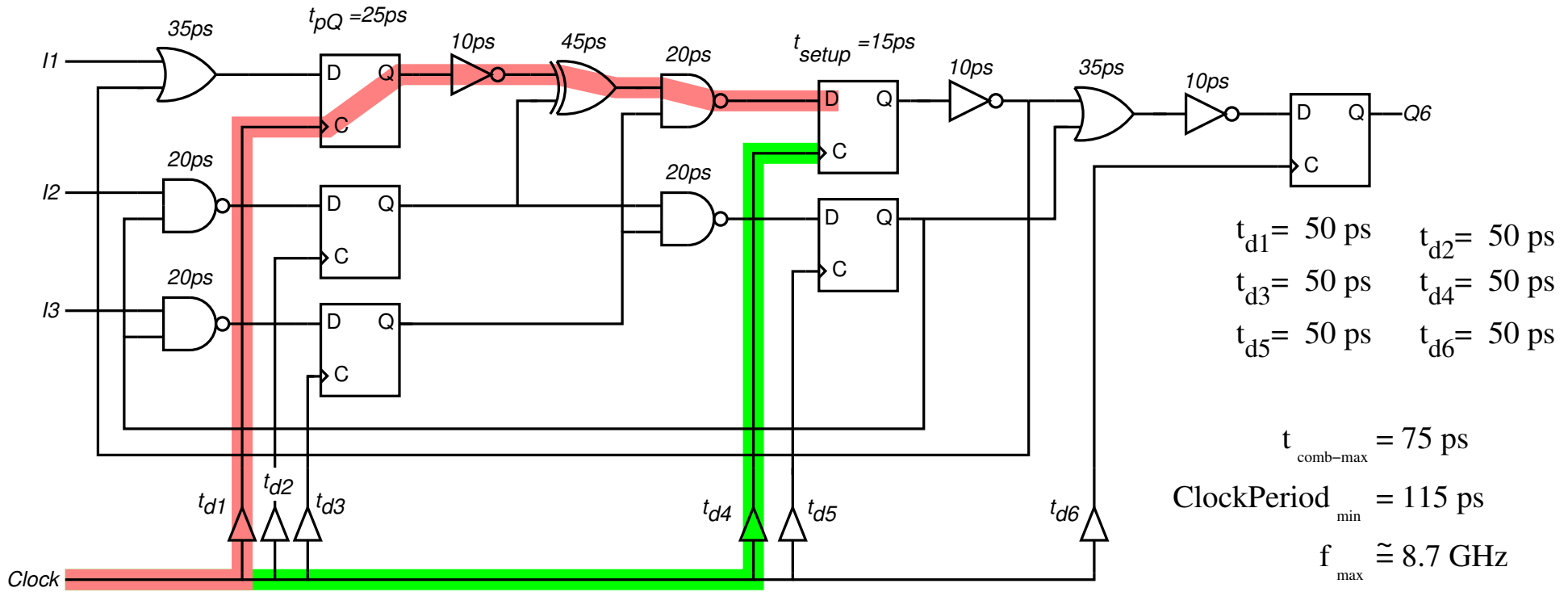

$$\text{ClockPeriod} > t_{pQ} + t_{\text{comb-max}} + t_{\text{setup}} + (t_{d1} - t_{d4})$$

$$f_{\text{max}} = \frac{1}{t_{pQ} + t_{\text{comb-max}} + t_{\text{setup}} + (t_{d1} - t_{d4})}$$

Synchronous Systems - Static Timing Analysis (inc. clock skew)

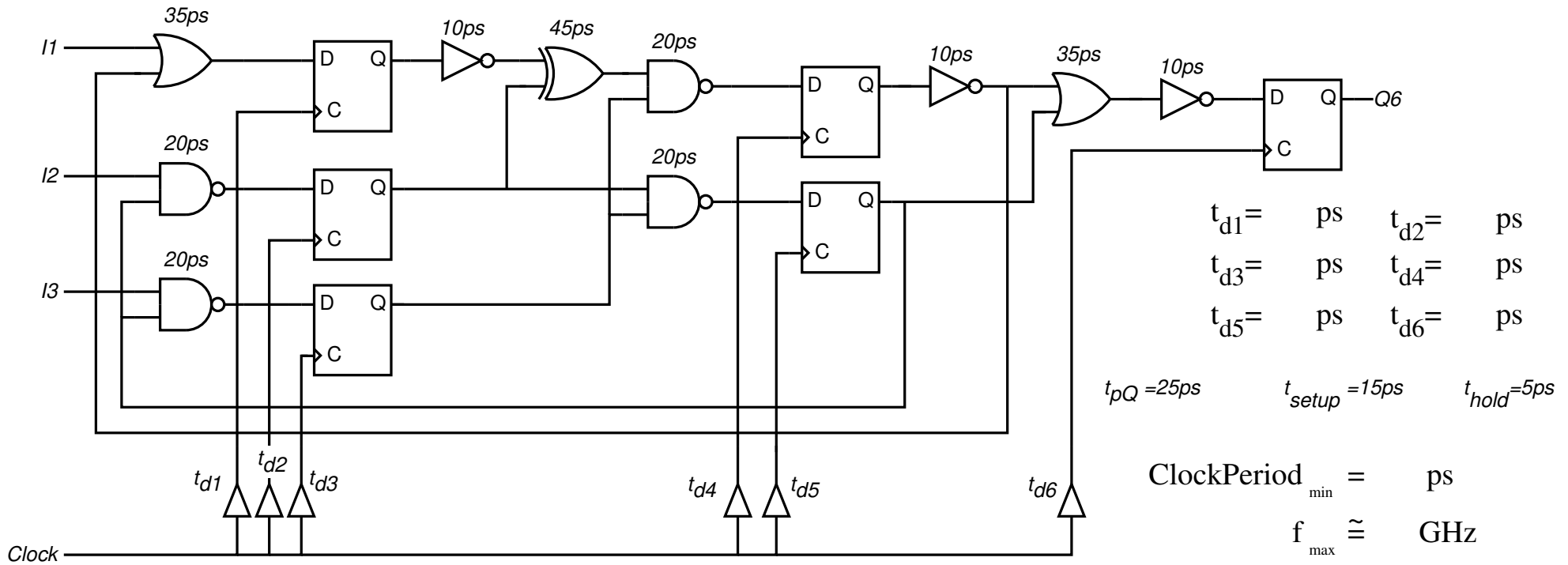

$$ClockPeriod > t_{pQ} + t_{comb-crit} + t_{setup} + (t_{d_{launch}} - t_{d_{capture}})$$

$$f_{max} = \frac{1}{t_{pQ} + t_{comb-crit} + t_{setup} + (t_{d_{launch}} - t_{d_{capture}})}$$

Synchronous Systems - Static Timing Analysis (inc. clock skew)

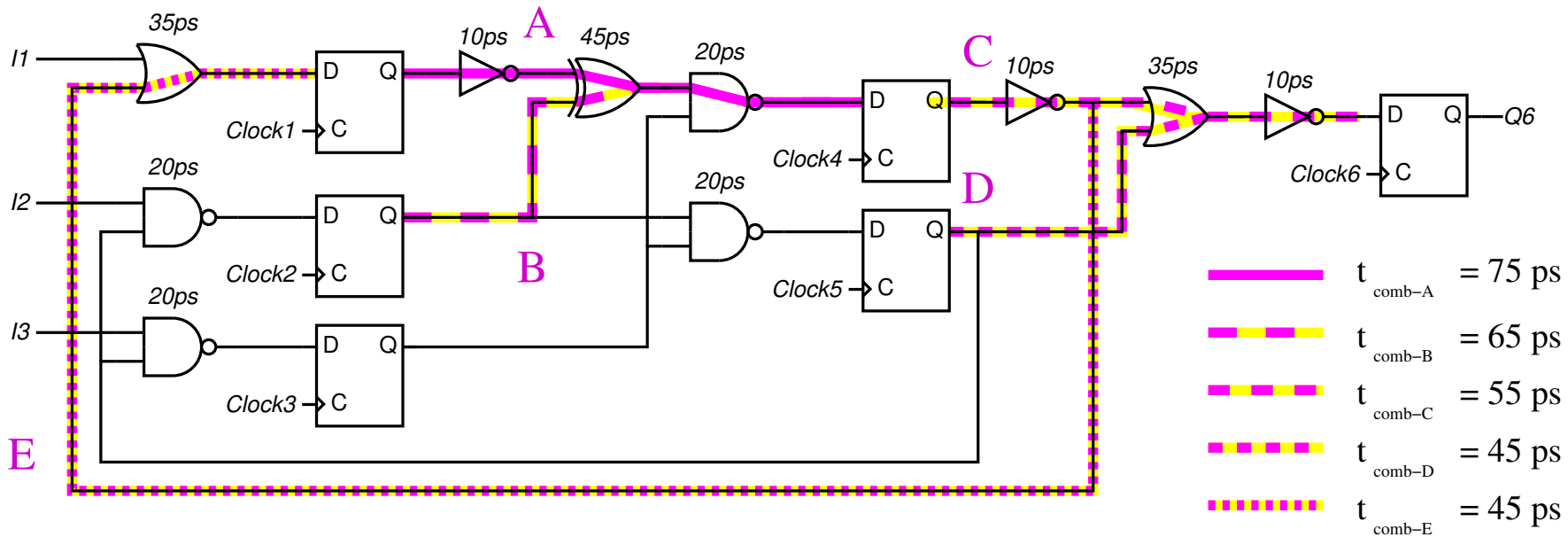

⇒ Initially try increasing t_{d4} by 20ps

Synchronous Systems - Static Timing Analysis (inc. clock skew)

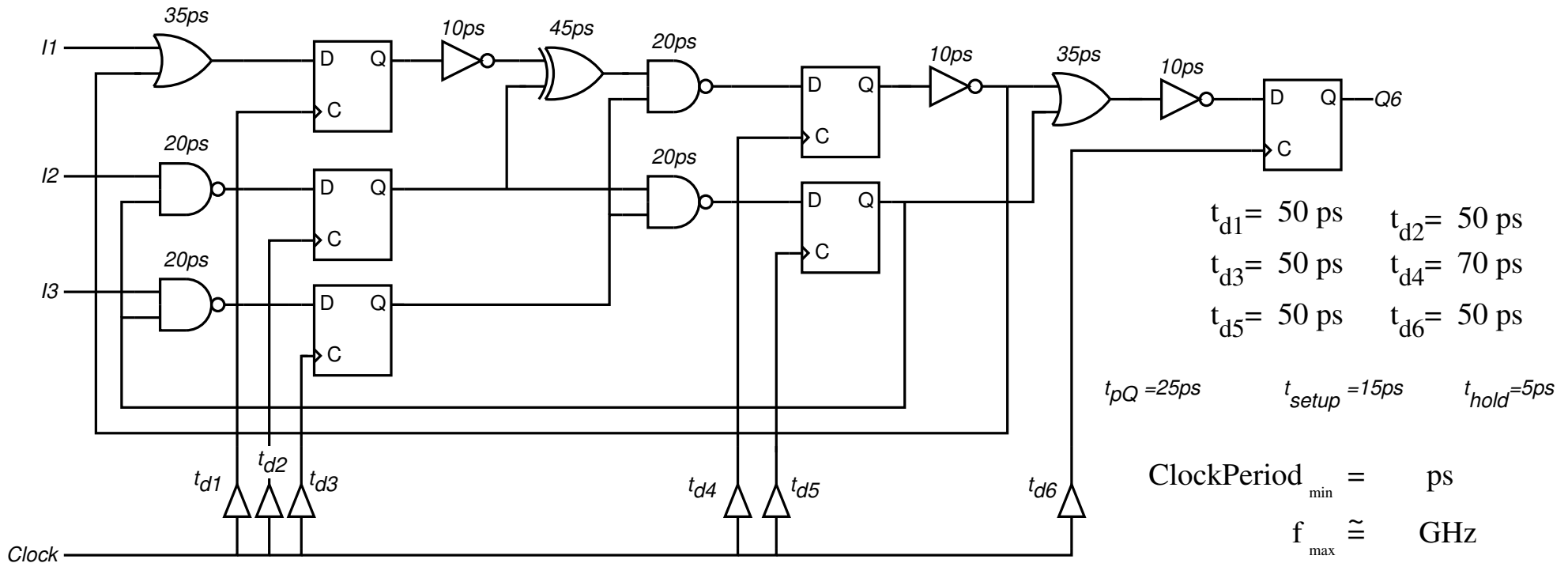

$$\text{ClockPeriod} > t_{pQ} + t_{\text{comb-crit}} + t_{\text{setup}} + (t_{d_{\text{launch}}} - t_{d_{\text{capture}}})$$

$$f_{\text{max}} = \frac{1}{t_{pQ} + t_{\text{comb-crit}} + t_{\text{setup}} + (t_{d_{\text{launch}}} - t_{d_{\text{capture}}})}$$

Synchronous Systems - Static Timing Analysis (inc. clock skew)

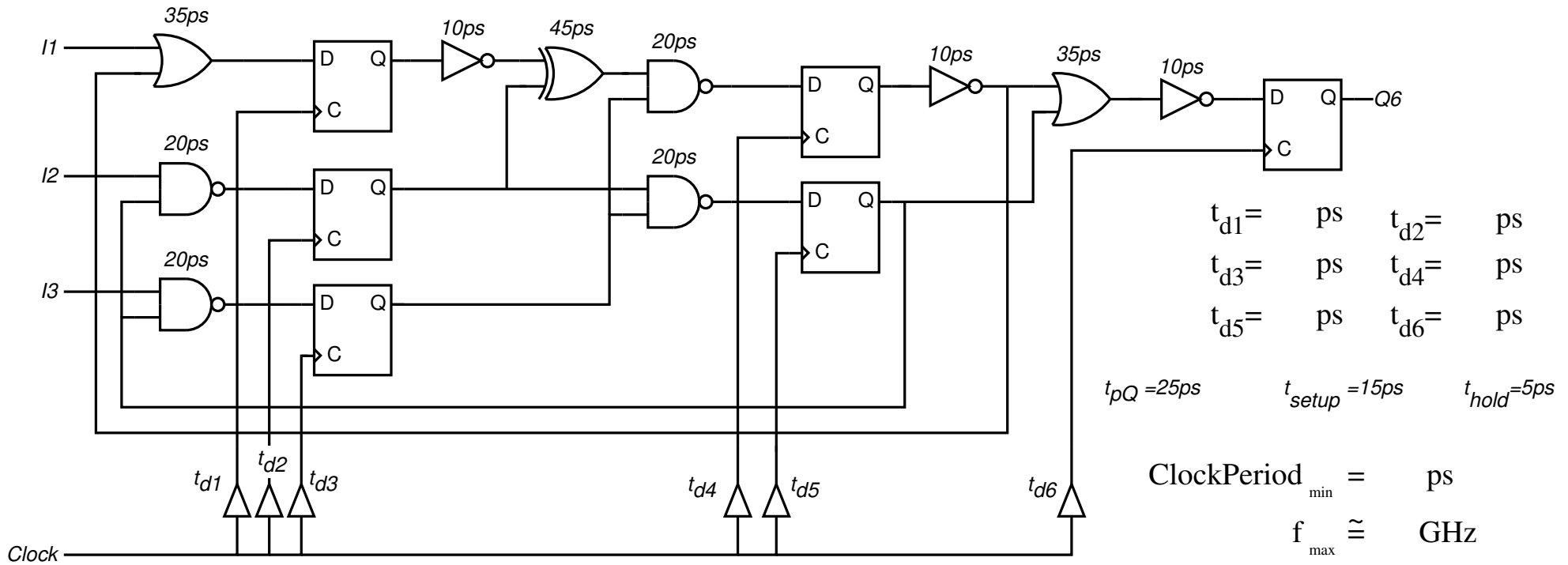

$$\text{ClockPeriod} > t_{pQ} + t_{\text{comb-crit}} + t_{\text{setup}} + (t_{d_{\text{launch}}} - t_{d_{\text{capture}}})$$

$$f_{\text{max}} = \frac{1}{t_{pQ} + t_{\text{comb-crit}} + t_{\text{setup}} + (t_{d_{\text{launch}}} - t_{d_{\text{capture}}})}$$

Synchronous Systems - Static Timing Analysis (inc. clock skew)

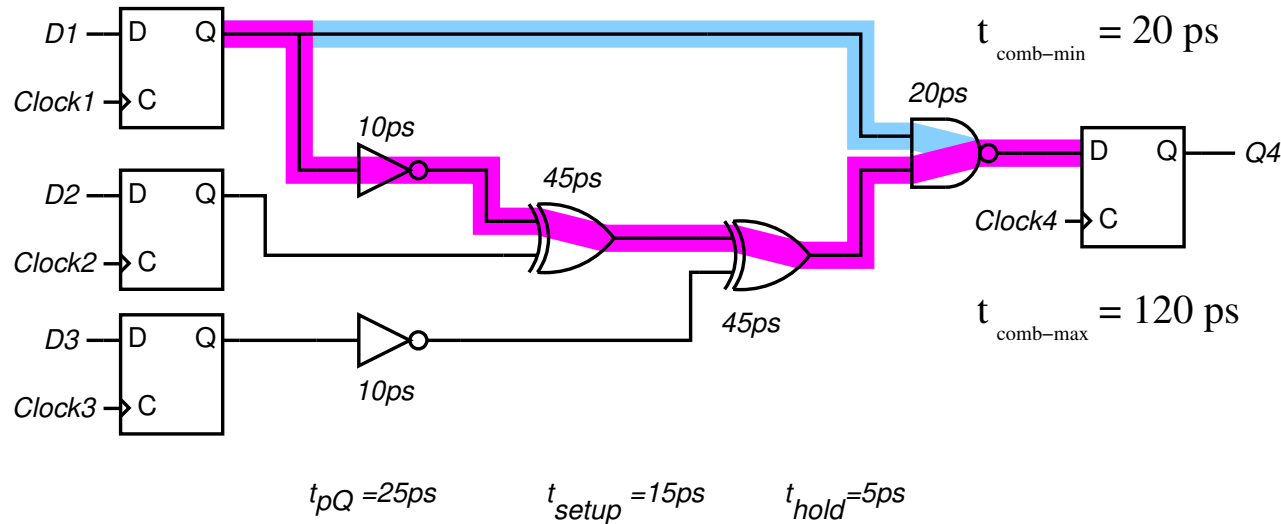

- Calculate f_{max} in the presence of intentional clock skew.
- Suggest suitable values for $t_{d1}, t_{d2}, t_{d3}, t_{d4}$ given that the minimum delay through the clock tree is 50ps

remember to check for hold violations

Synchronous Systems - Jitter

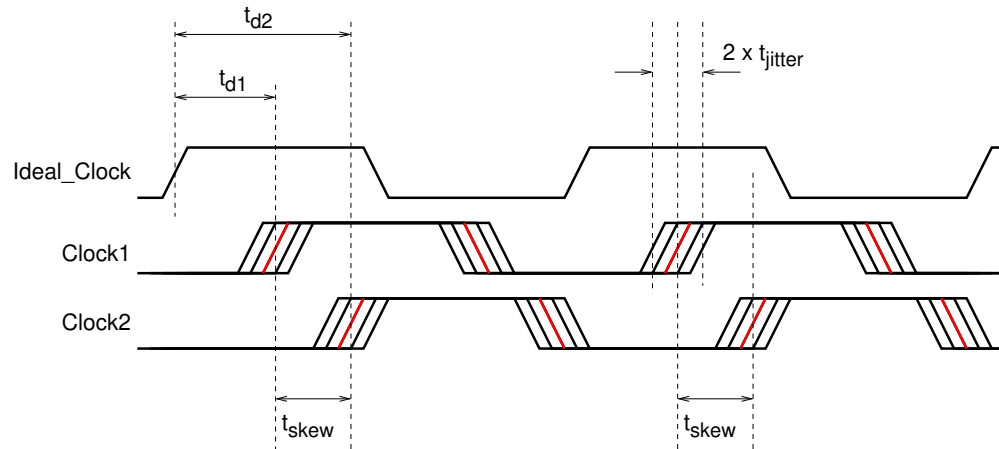

- Jitter

Jitter is the cycle-by-cycle variation in the arrival time of the clock.

- Caused by

- Variation in frequency/phase of clock source⁵
- Power supply noise affecting clock distribution
- Cross-talk affecting clock distribution

- Jitter may cause unexpected timing violations

⁵primary clock source or Phase-Locked Loop (PLL)

Synchronous Systems - Jitter

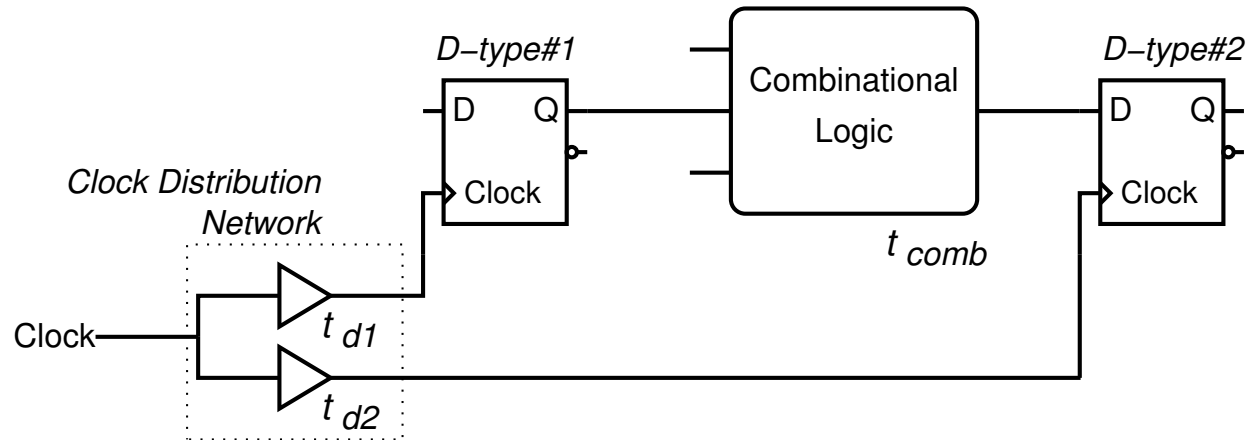

- To avoid a setup violation:

$$ClockPeriod > t_{pQ} + t_{comb} + t_{setup} + (t_{d1} - t_{d2}) + 2 \times t_{jitter}$$

- To avoid a hold violation:

$$t_{pQ} + t_{comb} > t_{hold} + (t_{d2} - t_{d1}) + 2 \times t_{jitter}$$

Synchronous Systems - Static Timing Analysis (skew + jitter)

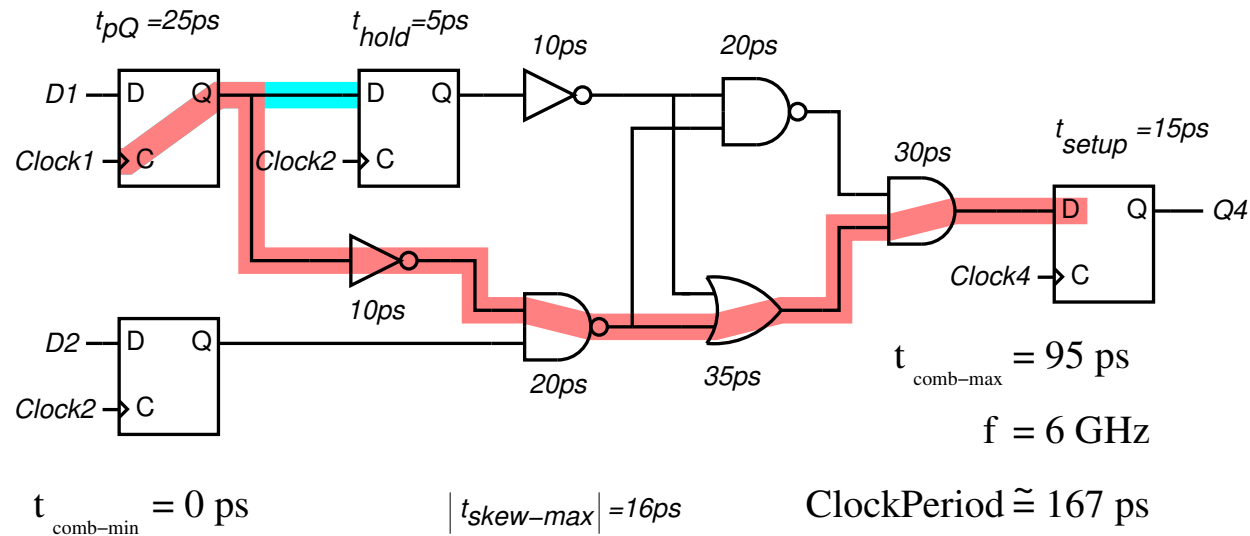

- What is the maximum jitter that can be tolerated given an operating frequency of 6GHz and clock skew of no more than 16ps?⁶

$$ClockPeriod > t_{pQ} + t_{comb-max} + t_{setup} + t_{skew} + 2 \times t_{jitter}$$

$$t_{pQ} + t_{comb-min} > t_{hold} + t_{skew} + 2 \times t_{jitter}$$

⁶remember to consider both setup and hold violations