

NMOS Transistor – with top substrate connection

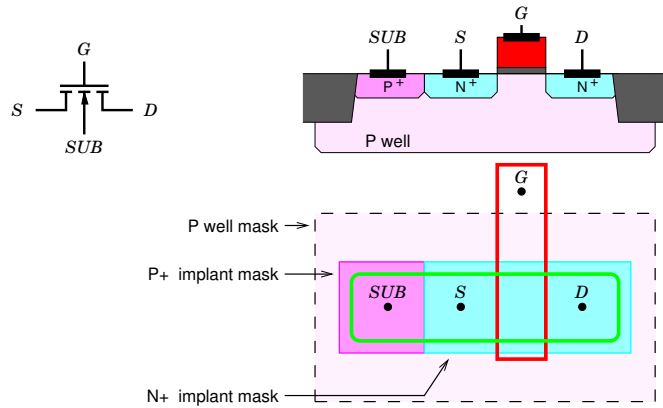

4001

CMOS Inverter

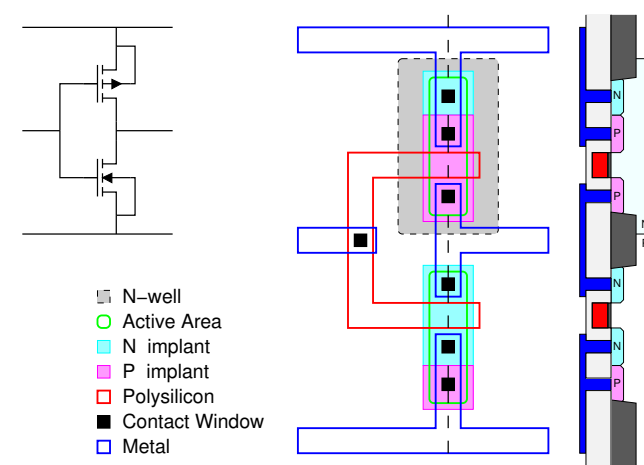

4003

NMOS Transistor – with top substrate connection

Where it is not suitable for substrate connections to be shared, a more complex process is used.

- Five masks must be used to define the transistor:
 - P Well
 - Active Area
 - Polysilicon
 - N+ implant
 - P+ implant
- P Well, for isolation.
- Top *substrate* connection.
- P+/N+ implants produce good *ohmic* contacts.

4002

CMOS Inverter

- The process described here is an *N Well process* since it has only an N Well. P Well and Twin Tub processes also exist.
- Note that the P-N junction between chip substrate and N Well will remain reverse biased. Thus the transistors remain isolated.
- N implant defines NMOS source/drain and PMOS substrate contact.
- P implant defines PMOS source/drain and NMOS substrate contact.

4004

Processing – Photolithography

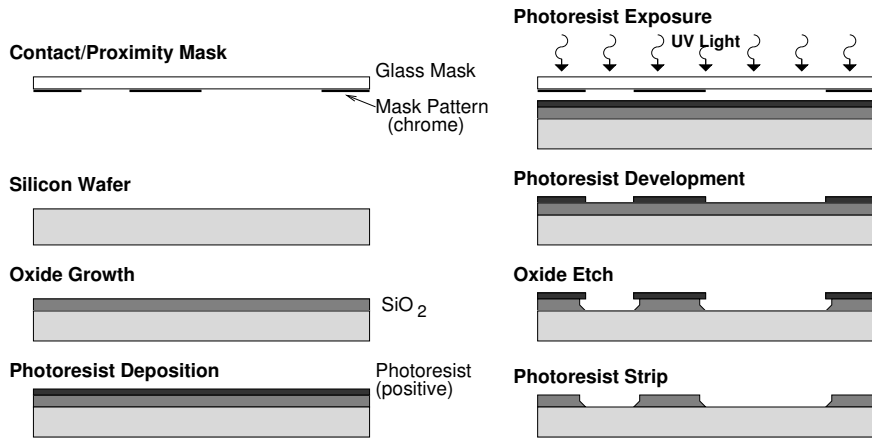

4005

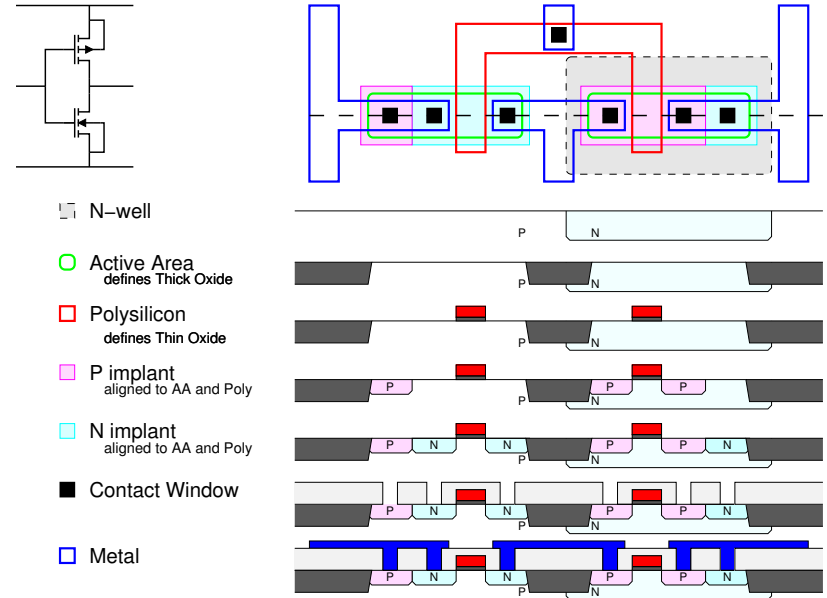

4007

Processing – Mask Making

Reticle written by scanning electron beam

Pattern reproduced on wafer (or contact/proximity mask) by step and repeat with optical reduction

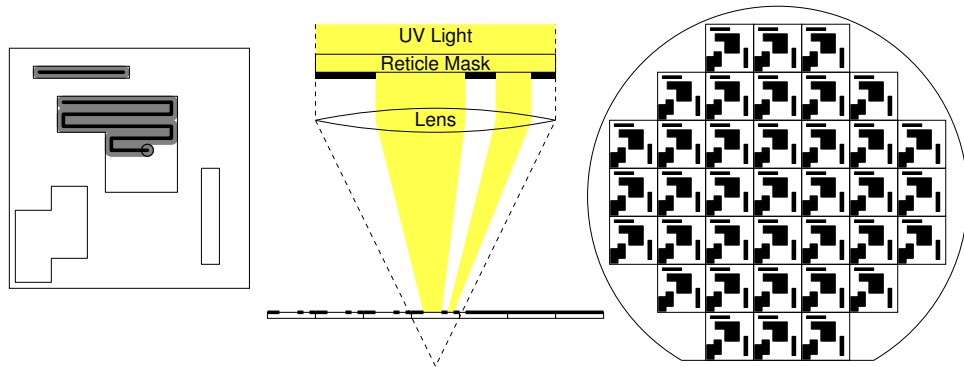

- Optical reduction allows narrower line widths.

4006

CMOS - Short Gate Techniques

Fin FET

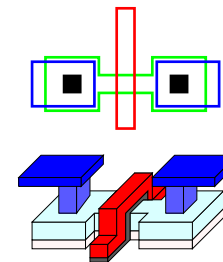

- With the aid of trenches we raise the active area above the bulk silicon.
- We can then wrap the gate around the channel.
- Avoids an effect where a channel is created in a region which is closer to the drain than the gate.

4008