

Latches and Flip-Flops

- CMOS transmission gate latch

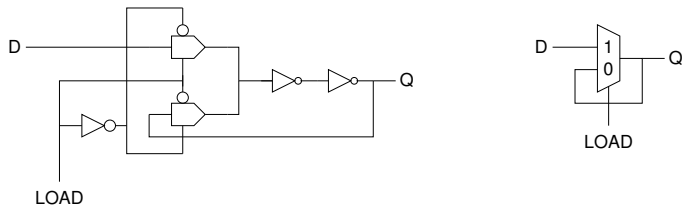

A simple transparent latch can be build around a transmission gate multiplexor

- transparent when load is high
- latched when load is low
- two inverters are required since the transmission gate cannot drive itself

8001

Latches and Flip-Flops

- A simpler layout may be achieved using tristate inverters.

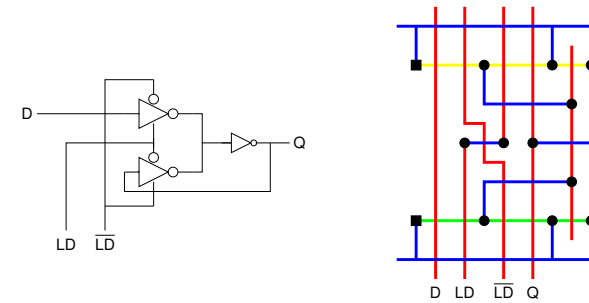

- this design requires two additional transistors but may well be more compact.

8003

Latches and Flip-Flops

- Transmission gate latch layout

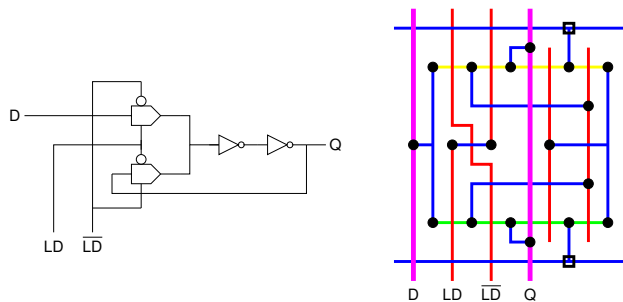

- a compact layout is possible using 2 layer metal

8002

Latches and Flip-Flops

- For use in simple synchronous circuits we use a pair of latches in a master slave configuration.

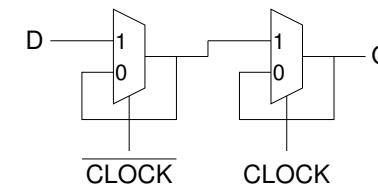

- this avoids the race condition in which a transparent latch drives a second transparent latch operating on the same clock phase.
- the circuit behaves as a rising edge triggered D type flip-flop.

8004

Latches and Flip-Flops

- Transmission gate implementation

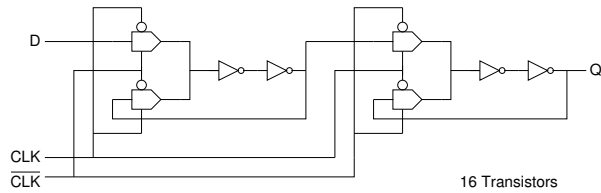

- Tristate inverter implementation

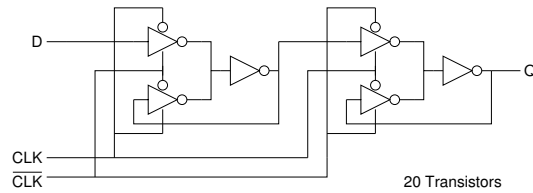

8005

Latches and Flip-Flops

- Layout of master slave D type.

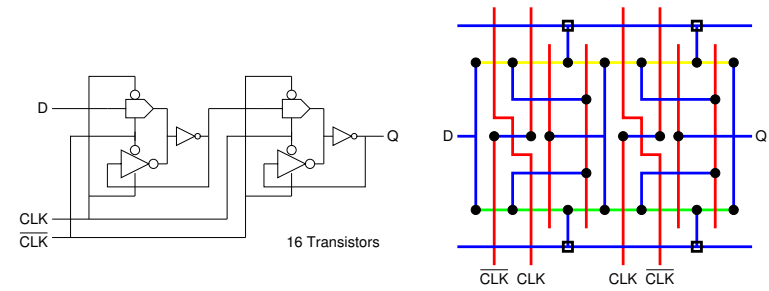

– very compact using alternative configuration.

8007

Latches and Flip-Flops

- Alternative configuration

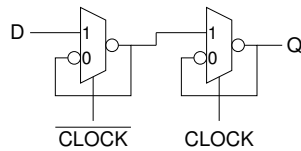

– Implementation

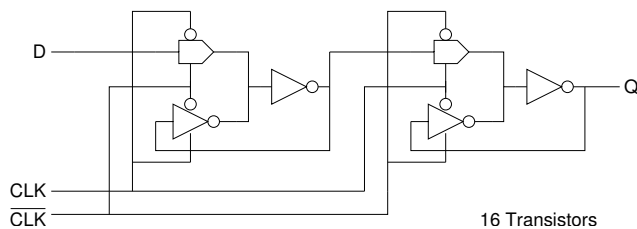

8006

Latches and Flip-Flops

- For the same functionality we could use an edge triggered D type:

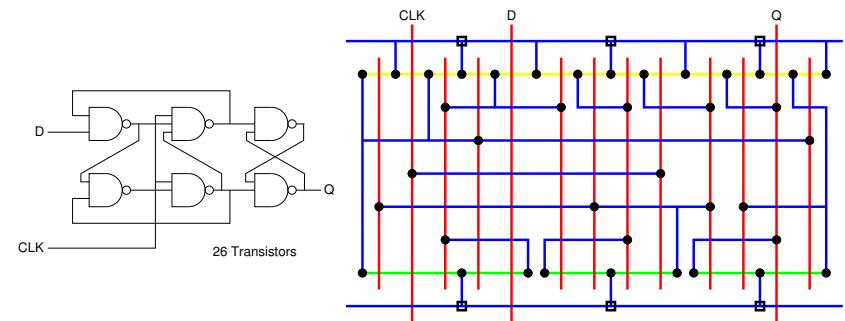

– a few more transistors
 – more complex wiring
 – simpler clock distribution

8008

Register File

Where we have large amounts of storage the use of individual latches can lead to space saving.

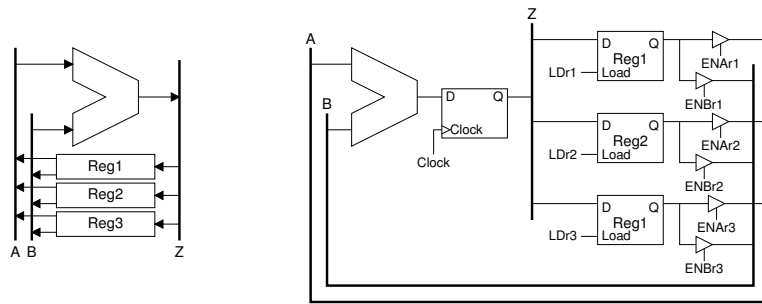

- Load signals must be glitch free with tightly controlled timing.
- Edge Triggered D-type prevents a race condition ($Reg1 \leftarrow Reg1 + Reg2$).