

Static CMOS Complementary Gates

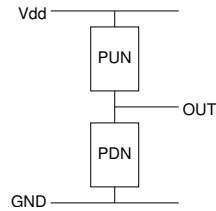

- **Static**

After the appropriate propagation delay the output becomes valid and remains valid.¹

- **Complementary**

For any set of inputs there will exist either a path to Vdd or a path to GND. Where this condition is not met we have either a high impedance output or a conflict in which the strongest path succeeds. Static CMOS **Non-complementary** gates make use of these possibilities.

¹c.f. Dynamic logic which uses circuit capacitance to store state for a short time.

7001

Pass Transistor Circuits

- **Transmission Gate**

– For static circuits we would normally use a CMOS transmission gates:

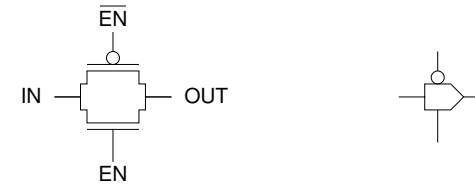

- balanced n and p pass transistors
- faster pull-up
- slower pull-down

7003

Pass Transistor Circuits

- **Pass Transistor**

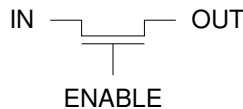

- Provides very compact circuits.
- Good transmission of logic '0'.
- Poor transmission of logic '1'.
 - slow rise time
 - degradation of logic value

The pass transistor is used in many dynamic CMOS circuits².

²where pull-up is performed by an alternative method

7002

Pass Transistor Circuits

- **Transmission Gate Layout**

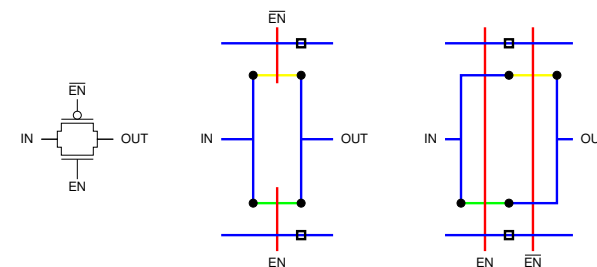

– note that these circuits are not fully complementary³ hence they do not immediately lend themselves to a *line of diffusion* implementation.

³since there are sets of inputs for which the output is neither pulled low nor high

7004

Pass Transistor Circuits

• Transmission Gate Multiplexor

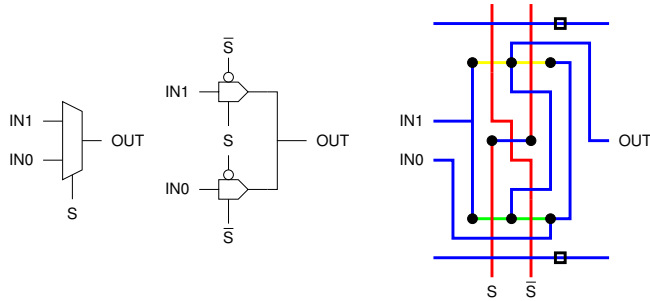

- very few transistors 4 (+2 for inverter)
- difficult layout may offset this advantage
- - prime candidate for 2 level metal

7005

Bus Distributed Multiplexing

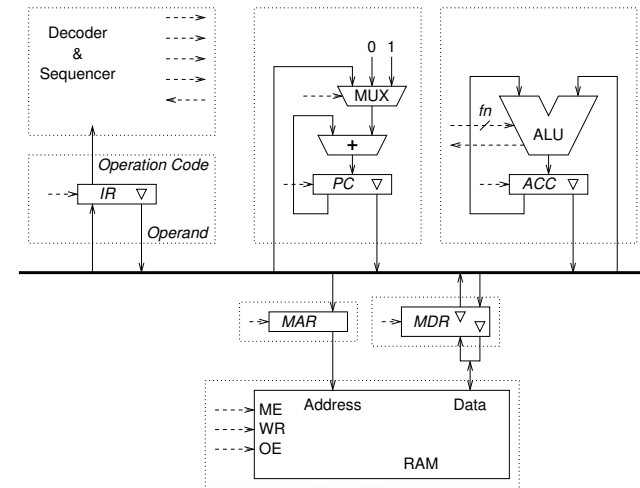

Ideal for signals with many drivers from different modules.

7007

Pass Transistor Circuits

• Bus Wiring

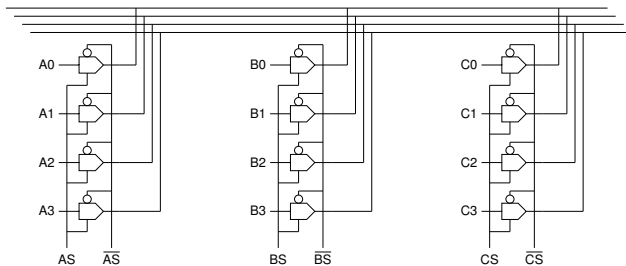

- distributed multiplexing⁴
- only one inverter required per bank of transmission gates
- greatly simplifies global wiring

⁴internal chip bus should never be allowed to float high impedance

7006

Bus Distributed Multiplexing

Implementation of bitslice ALU:⁵

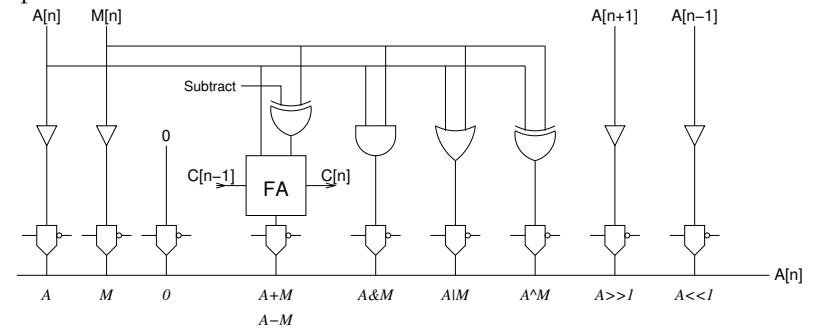

- Separate circuit for each function
- Connected via distributed multiplexor

⁵Note that transmission gates have no drive capability in themselves. Here a good drive is ensured by providing buffers.

7008

Bus Distributed Multiplexing

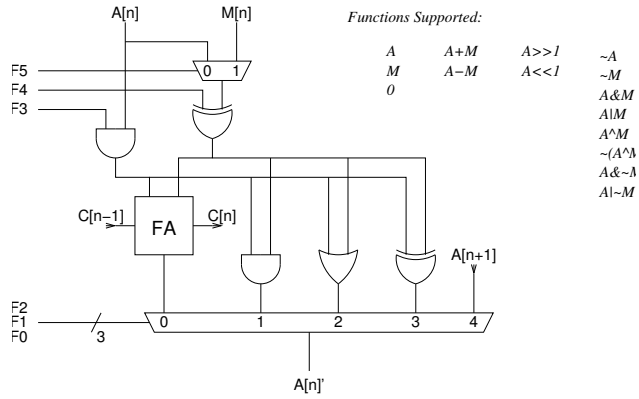

- Single optimized ALU module
- Multiplexing is not distributed
- Multiplexor implementation may use transmission gates

7009

Pass Transistor Circuits

- Tristate Inverter

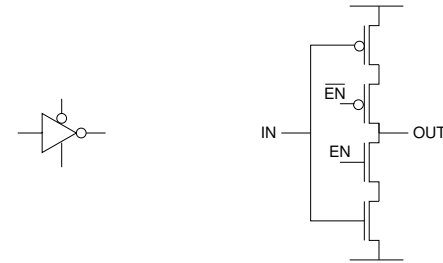

- Alternatively the transmission gate may be incorporated into the gate.
 - one connection is removed - easier to layout
 - also easier to simulate!

7011

Pass Transistor Circuits

- Tristate Inverter

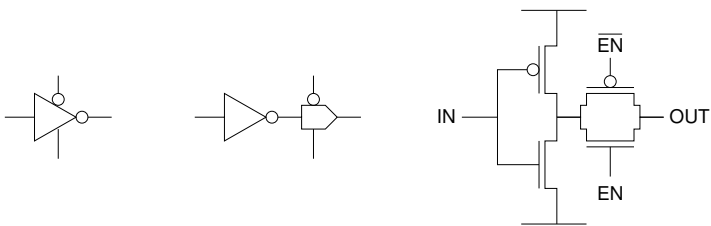

- Any gate may have a tri-state output by combining it with a transmission gate.

7010

Pass Transistor Circuits

- Tristate Inverter Layout

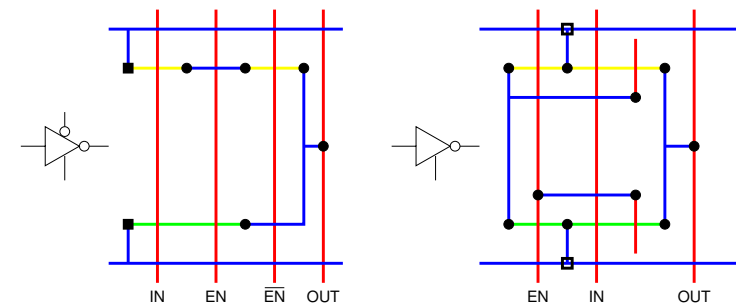

7012

Pass Transistor Circuits

- Tristate Inverter Bus Driver

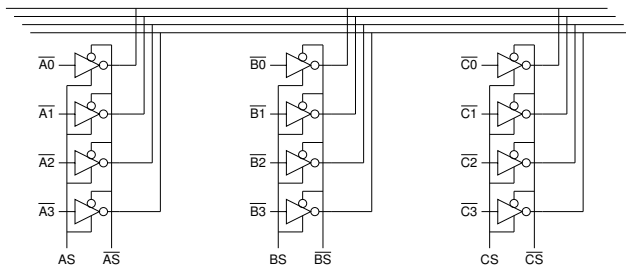

- a tristate inverting buffer is often used to drive high capacitance bus signals
- transistors may be sized as required