

PMOS Enhancement transistor CMOS Process

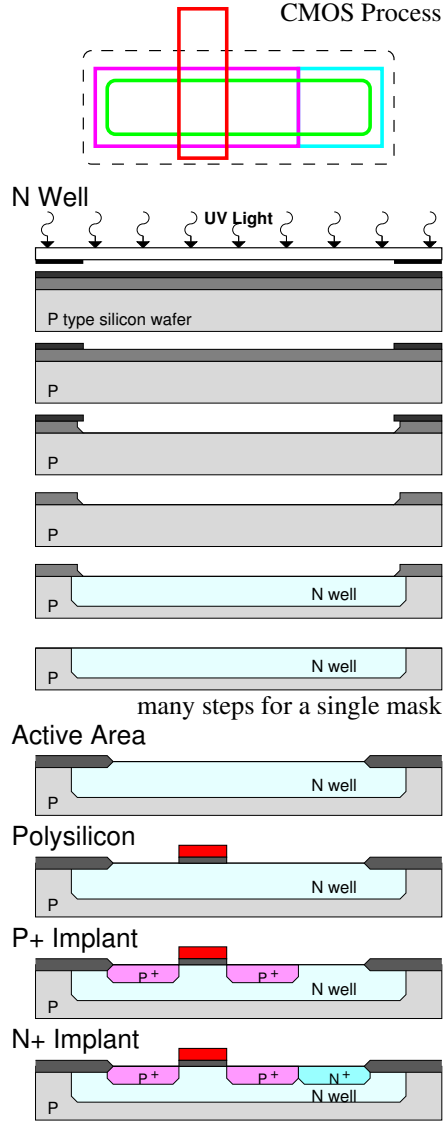

CMOS Inverter Twin Tub CMOS Process

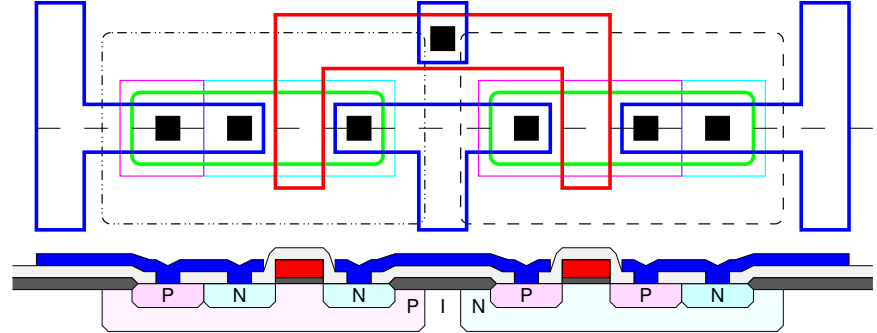

CMOS Inverter N-Well CMOS Process (with explicit N+ implant mask)

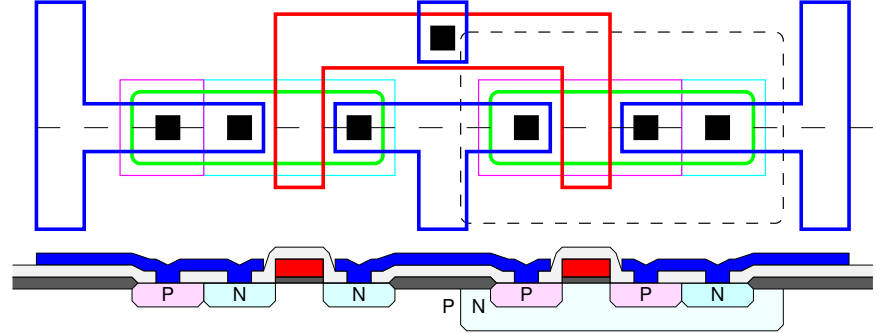

CMOS Inverter N-Well CMOS Process (without explicit N+ implant mask)

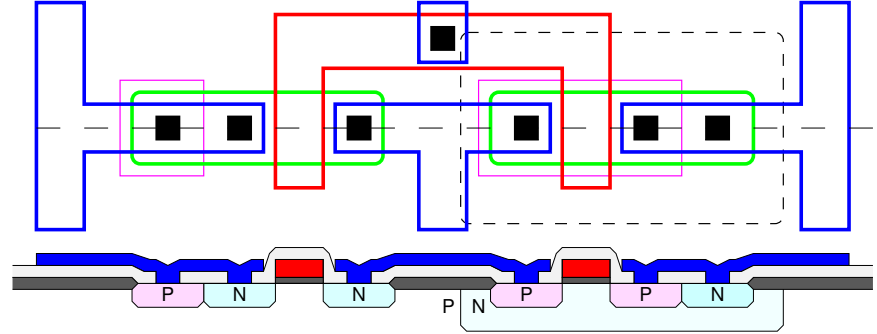

Features may be determined by a number of masks
 e.g. NMOS source drain: ActiveArea AND NOT(NWell OR Poly OR PImplant)