

MTM2

Mini-Traction Machine

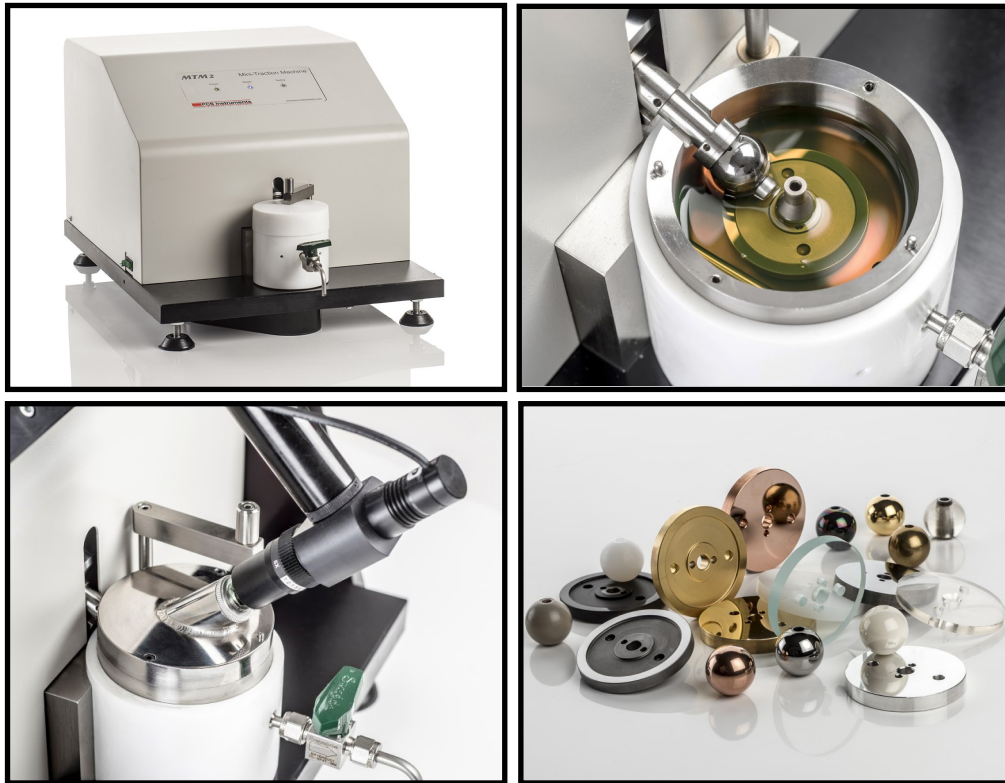

A bench top, computer controlled, precision traction measurement instrument which provides fully automated traction mapping of lubricants and other fluids

MTM2 Overview

The MTM1 and the updated MTM2 have between them sold over 200 systems worldwide. It is a flexible general purpose instrument for measuring the frictional properties of lubricated and unlubricated contacts under a wide range of rolling and sliding conditions. One of the main applications is the fully automated traction mapping of lubricants under conditions commonly found in internal combustion engines. Additional features allow the measurement of anti-wear additive film growth on test specimens, investigation of soft contacts, reciprocating friction and wear measurements.

Principle

In the standard configuration the test specimens are a 19.05mm (3/4 inch) steel ball and a 46 mm diameter steel disc. The ball is loaded against the face of the disc and the ball and disc are driven independently to create a mixed rolling/sliding contact. The frictional force between the ball and disc is measured by a force transducer. Additional sensors measure the applied load, the lubricant temperature and (optionally) the electrical contact resistance between the specimens and the relative wear between them.

Automated testing

The control software runs on a standard PC and allows the user to easily define a test profile containing a sequence of temperatures, loads and speeds. The selected profile steps the instrument through the test sequence, recording data as required, without any intervention by the user. The design parameters of the instrument have been carefully chosen so that high contact pressures, temperatures and speeds can be attained within a safe, easy to use laboratory bench top system.

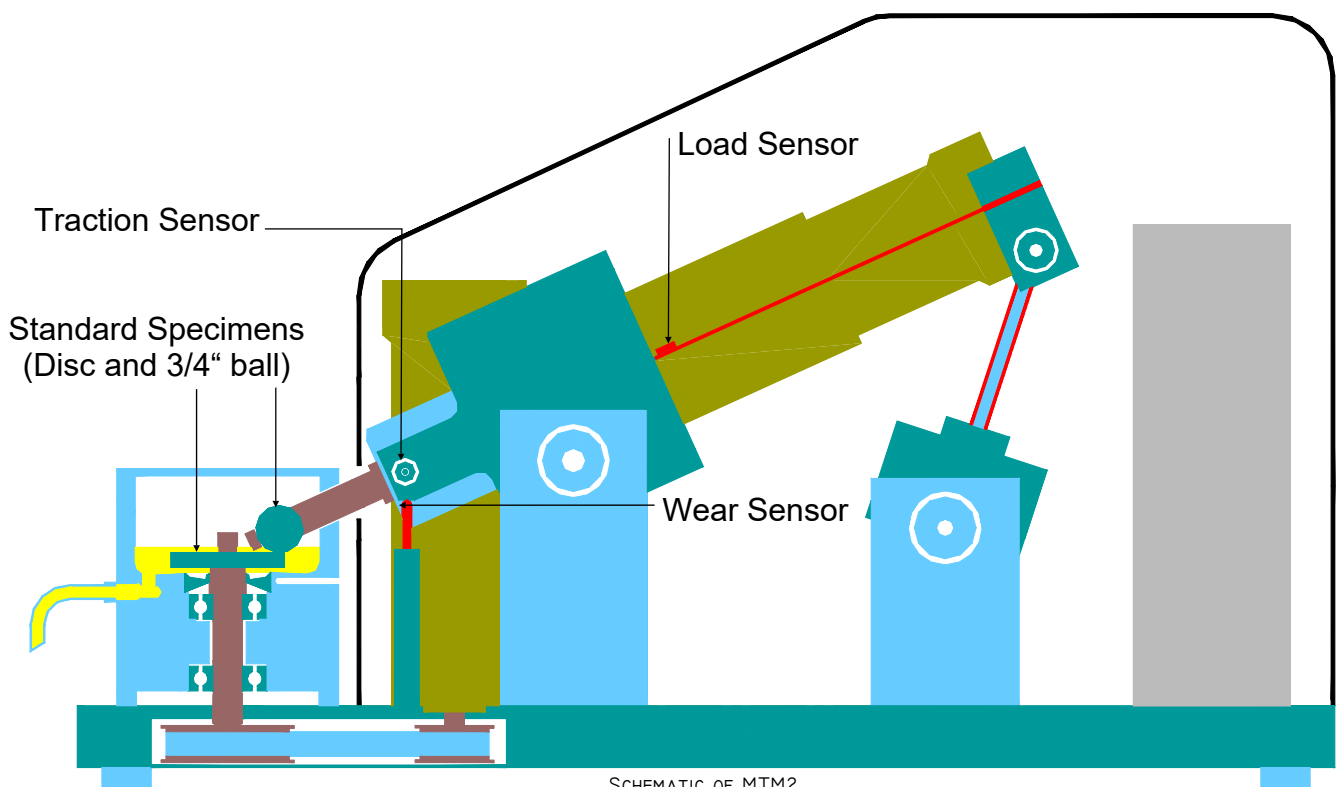

Specimens

The standard ball and disc specimens can be made from almost any combination of materials, including metals, ceramics, polymers, elastomers and coated substrates. The simple specimen geometry and small size means that the specimens are usually sufficiently inexpensive such that they can be treated as single-use.

Traction and Stribeck data

Below are screen shots from two traction and two Stribeck tests performed on the MTM2 for a mineral oil (top) and a 75W-90 Gear oil (bottom). Test conditions: Load, 37N (1GPa contact pressure), speed 0-2m/s, slide/roll ratio (SRR) 0-70%, temperature, 40, 60, 80, 100, 120°C.

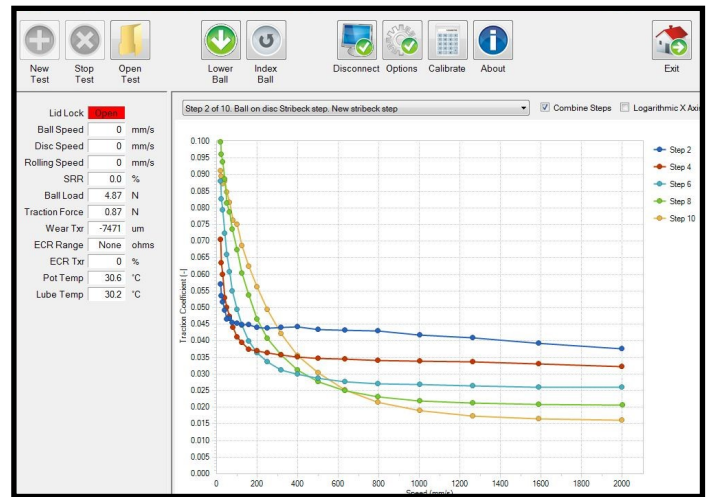
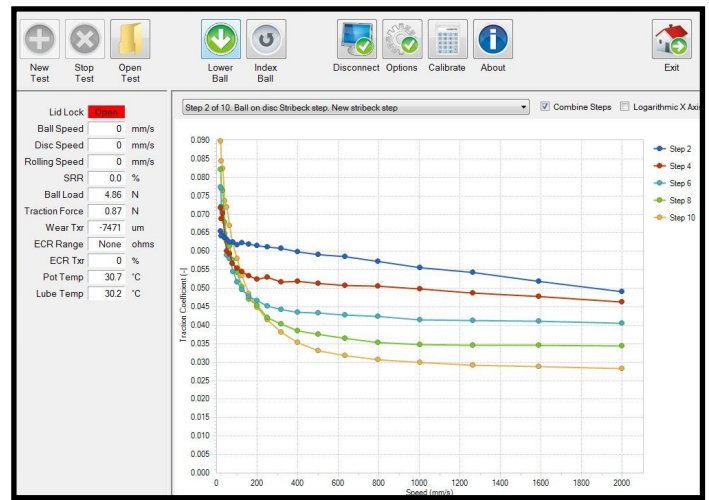
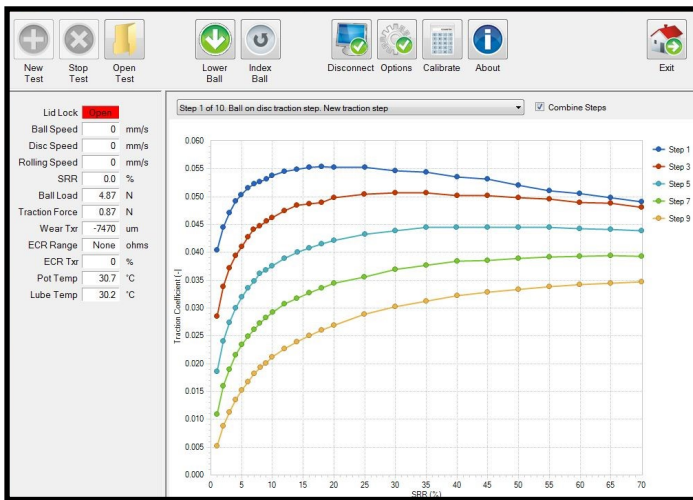

MTM2 Options

3D Spacer Layer Imaging Method (SLIM) enables the instrument to measure additive film formation on the test ball during the course of a test. This option is of great benefit to users who are designing and developing lubricants and additive packages.

Electrical contact resistance (ECR) gives an indication of surface interaction between the two specimens.

Reciprocating option enables the disc to be driven with a sinusoidal motion, further expanding the range of contact conditions which can be created.

3D-SLIM Option: Film Thickness Measurement

Principle

The 3D spacer layer imaging (3D-SLIM) option uses optical interferometry to measure sub-micron additive films on the specimens as they form during the test. To make the measurement the steel test ball is loaded against a glass disc coated with a chromium and silica layer. The contact is illuminated by a white light source directed down a microscope and through the glass disc. Part of the light is reflected from the chrome layer on the disc and part travels through the silica layer and any additive film and is reflected back from the steel ball. The recombining light paths form an interference image which is focused onto the imager of a high resolution RGB camera. The camera image is captured by a digital frame grabber and can be analysed by the control software to determine a film thickness map of the contact.

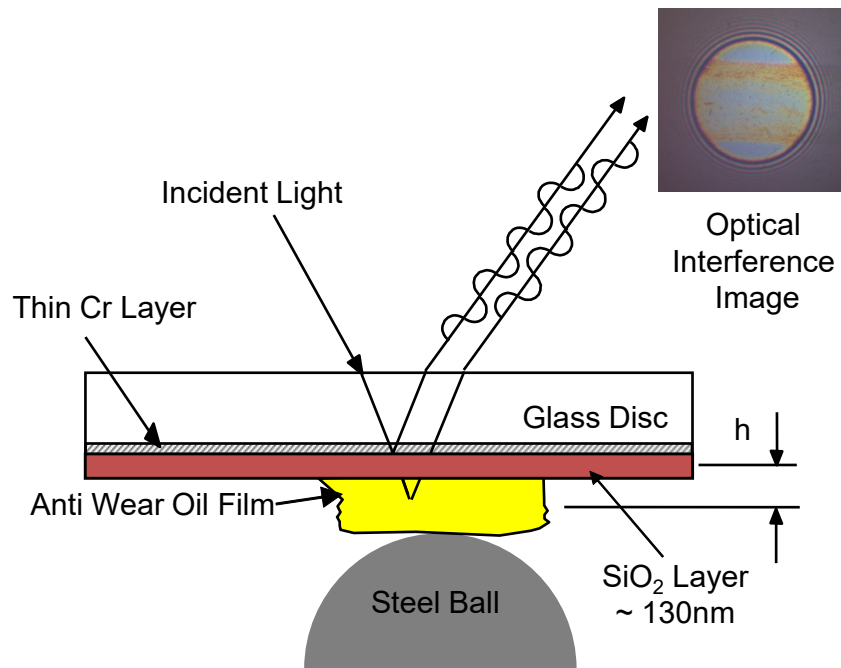

OPTICAL INTERFERENCE TECHNIQUE USED ON THE MTM2

To perform the test the steel ball is loaded against the steel disc and run under mixed sliding/rolling conditions for a fixed duration. Periodically throughout the test, the ball is stopped, loaded in reverse against the glass disc and a film thickness map of the complete contact area is captured. This allows film thickness measurements to be captured of any reaction films as they form. When used in tandem with the friction measurement, this provides a full, real time picture of both the chemical and physical effects of the films formed in the contact.

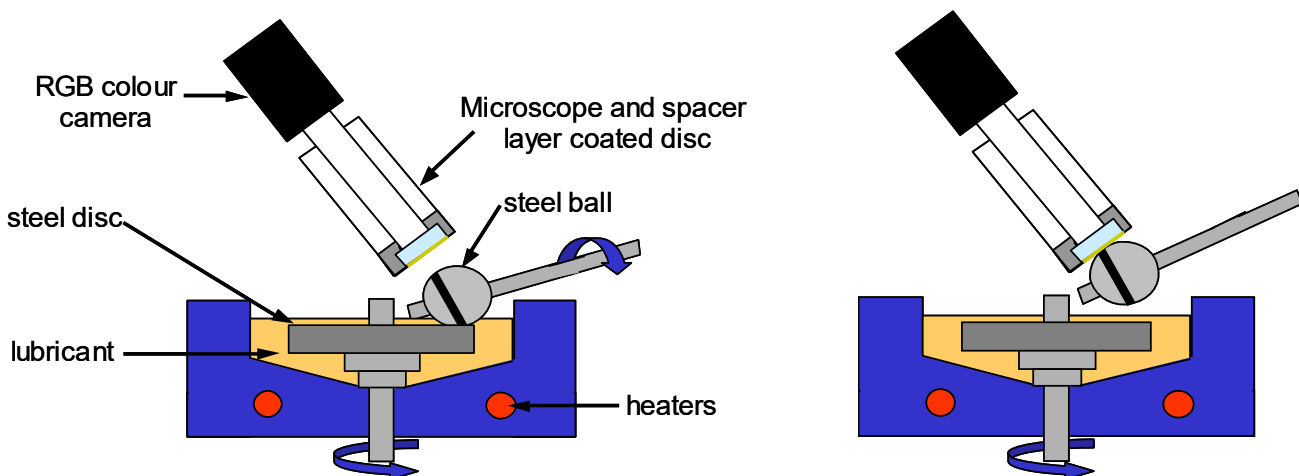

STEP 1 - THE TEST BALL IS RUN AGAINST A STEEL DISC FOR A PRE-DEFINED TIME

STEP 2 - AT A PRE-DEFINED TIME, THE TEST BALL IS REVERSE LOADED AGAINST A COATED GLASS DISC, AN IMAGE IS CAPTURED BEFORE THE BALL IS LOWERED AND THE TEST CONTINUES.

Analysis

Once the test is completed the images are analysed using a stand alone analysis program. This can be done on the PC connected to the MTM2 or the images can be moved to another PC. The analysis program matches colours in the image to the calibration data supplied with the instrument to determine the film thickness at every point in the image up to a maximum film thickness of about 250nm. This allows the user to generate a complete film thickness map of the contact area or point and line measurements of a specific area of interest. The analysis program writes out the film thickness data as a text file which can be loaded into the supplied visualisation package or into a spreadsheet or other viewing software.

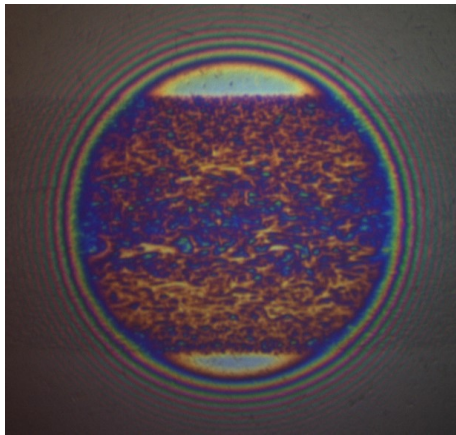
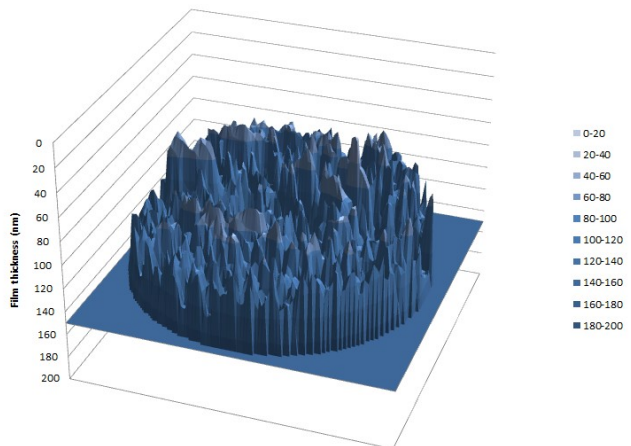

IMAGE TAKEN DURING TEST



3D SURFACE MAP

Applications

Two recent trends in engine oil formulation are a progressive reduction in phosphorus concentration and an increase in dispersant concentration. Both of these trends make it more difficult to generate and retain effective antiwear films on lubricated surfaces. The MTM2 has been shown as a suitable test method for monitoring antiwear film thickness during rolling/sliding and to explore how various factors, including operating temperature, antiwear additive type and concentration, and the presence of dispersant, influence both the formation and removal of the tribofilms formed by the antiwear additive zinc dialkyldithiophosphate (ZDDP)¹.

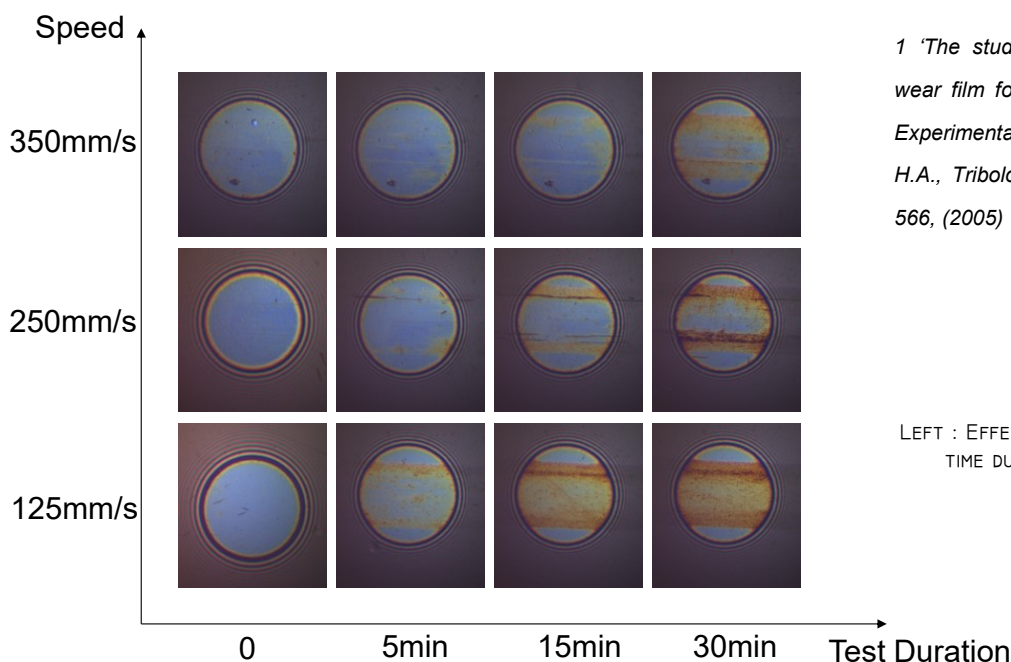

1 'The study of zinc dialkyldithiophosphate antiwear film formation and removal process. Part I: Experimental', Fujita, H., Glovnea R.P. and Spikes, H.A., *Tribology Transactions Volume 48*, pp 558-566, (2005)

LEFT : EFFECT OF RUBBING SPEED AGAINST TIME DURING AN MTM2 SLIM TEST

Wear Measurement and Testing

A number of new capabilities have been developed to expand the range of applications which can be simulated using the MTM2.

Bi-directional capability - high sliding speed

The bi-directional capability is fitted as standard on the MTM2. This allows the ball and disc motors to be driven in opposite directions, whilst still accurately controlling the speed. With this feature slide/roll ratios (SRR's) can be greater than 200%. Keeping a low entrainment speed maintains the contact in the mixed lubrication regime, while the high sliding speed accelerates the wear rate. This is particularly useful when evaluating lubricant anti-wear properties or scuffing resistance.

SRR (%)	Disc speed (ms ⁻¹)	Ball speed (ms ⁻¹)	Entrainment speed (ms ⁻¹)	Sliding speed (ms ⁻¹)
25	4.5	3.5	4	1
100	1.5	0.5	1	1
200	1	0	0.5	1
1000	0.6	-0.4	0.1	1
2000	0.55	-0.45	0.05	1
10,000	0.51	-0.49	0.01	1

SLIDING SPEED | MS⁻¹ WITH VARYING ENTRAINMENT SPEEDS

BLUE = BI-DIRECTIONAL SPEED CONTROL

On-line wear measurement

The MTM2 is fitted with a high precision on-line wear measurement system. A wear sensor automatically logs the displacement of the ball shaft with a one micron resolution during the test.

Pin-on-disc option

A stationary ball or pin loaded against the disc may be more appropriate to some test applications. With this option the ball shaft is fixed and the pin holder enables a wide range of upper specimen geometries to be loaded against the disc.

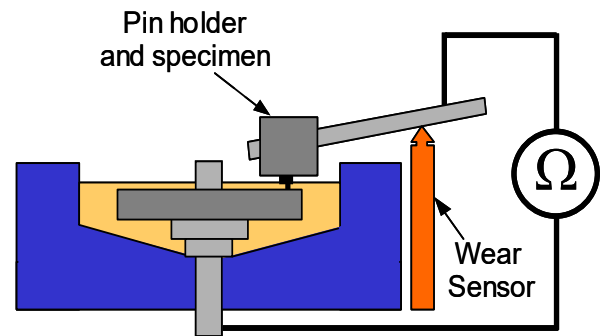

ECR EQUIVALENT CIRCUIT,

WEAR SENSOR AND PIN SPECIMEN

Electrical contact resistance (ECR) option

The ECR option gives an indication of surface interaction. The disc drive is electrically insulated from the ball and the electrical contact resistance between the two specimens is logged during the test.

Application

The MTM2 has been successfully used to assess the scuffing resistance of different oils. Both the friction coefficient and film thickness are measured against increasing load at high sliding speed. As the load increases, the friction initially drops and then rises significantly as the film collapses.

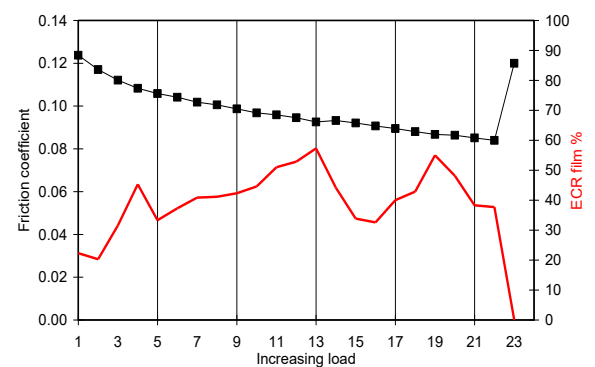

WHEN SCUFFING OCCURS, BOTH FRICTION AND ECR FILM SIGNALS SHOW AN ABRUPT CHANGE

Reciprocating option

For some applications, particularly when studying the behaviour of a lubricant under dynamic conditions, an oscillating motion is more representative than a continuously rotating disc. The reciprocating option changes the rotation of the disc into a reciprocating cycle, expanding the range of test conditions available on the MTM2.

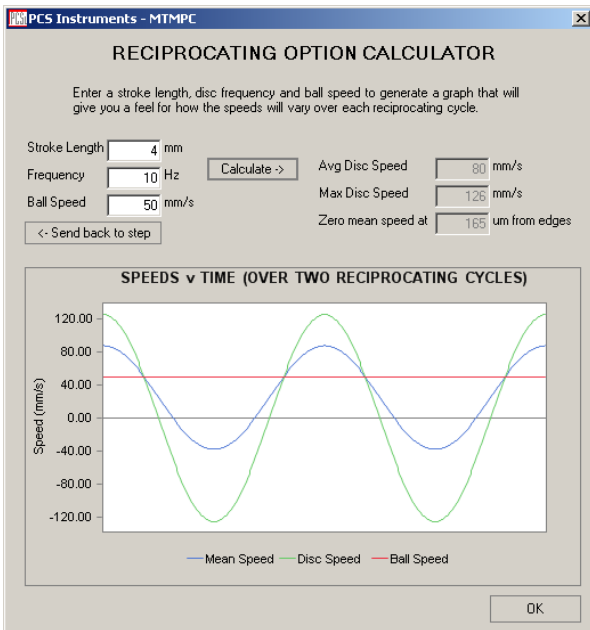

DISC AND MEAN SPEED CYCLES CAN BE SIMULATED IN THE CALCULATOR FOR AN EASY CHOICE OF TEST CONDITIONS

With the reciprocating option the disc can be oscillated at very low frequencies, from 0.1 to 20 Hz. Such low frequencies of oscillation can create very severe contact conditions and therefore accelerated wear. This can be very useful when evaluating the anti-wear properties of lubricant and additive packages.

The MTM2 reciprocating option offers many advantages over the conventional reciprocating ball-on-disc test. The ball can either be stationary as in the conventional test or have a unidirectional rotation. When the ball rotation is combined with the oscillating disc, a number of unusual dynamic motions can be simulated.

A typical example is simulating the motion found between a cam and follower.

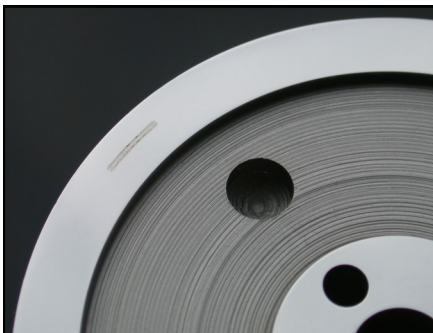

1

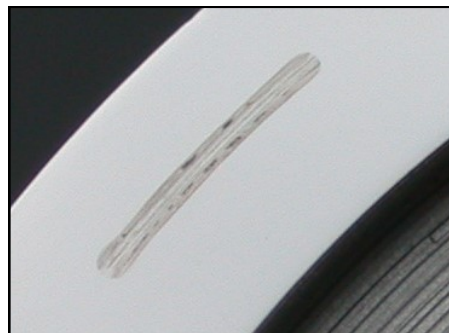

2

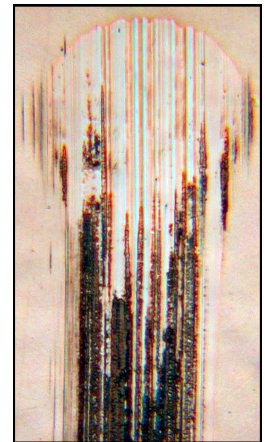

3

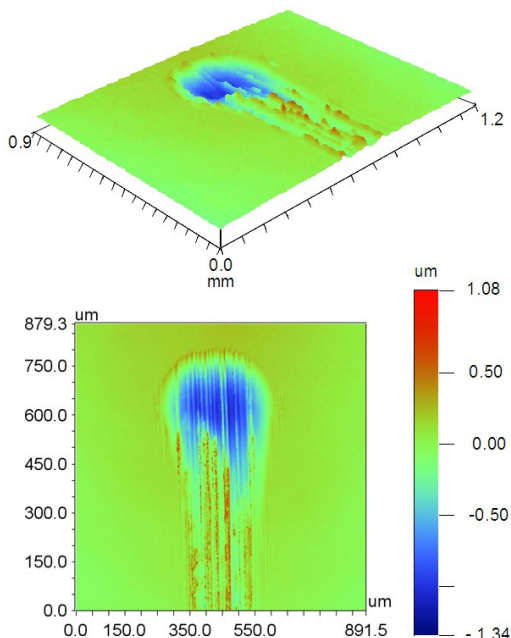

4

Cam follower simulation

Standard cam follower wear tests are costly both in terms of money and time. The reciprocating option makes it possible to perform these tests more quickly and cheaply. The pictures above show the wear scar on the disc after the test (1 & 2). Observation under microscope (3) reveals severe wear near the extremity of the scar, where the entrainment speed changes direction. The wear scar is deep enough to be measured with a profilometer (not supplied). View 4 shows 2D and 3D maps generated with an optical profilometer. The wear scar can also be measured with a standard contacting profilometer.

Soft Contact Investigation

The characteristics of soft contacts are different from the more usual steel on steel contact. The low stiffness of soft materials means that there is considerable elastic deformation of the specimens under load. Furthermore, the elastic hysteresis of the materials means that there is significant rolling friction in addition to the usual sliding friction. The MTM2 has been designed with the study of soft contacts in mind through the addition of load feedback and a capability to calculate both the sliding and rolling friction. In addition the MTM2 offers great flexibility when choosing specimens to create soft contacts.

Soft specimens selection

Several options are available to produce a soft compliant contact in the MTM2. The upper specimen can be a soft ball or a readily available standard size O ring supported by the O ring holder as show on the right. Alternatively custom made specimens can easily be produced.

The simple plane shape of the disc means it can be made of virtually any material and supported by a backing plate.



O RING HOLDER IN PLACE IN MTM2
FOR O RINGS OF SECTION 3 MM, ID 12.5 MM

Applications

The MTM2 has been used to study a wide variety of soft contact applications, including research on foods, cosmetics, seal materials and rubber shoe to ground contact.

Soft discs have been particularly successful when used to carry out fundamental research on food components and cosmetics. When using the reciprocating option, the MTM2 can reproduce the low frequency oscillation typically found in food processing or skin cream applications.

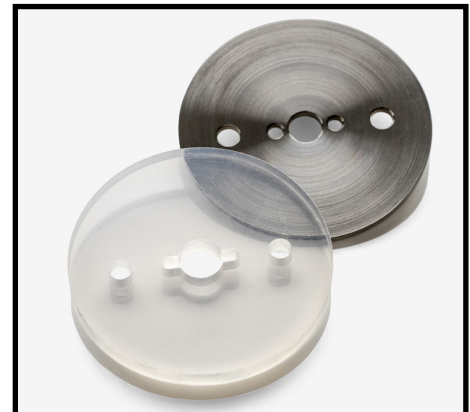

EXAMPLES OF SILICON ELASTOMER GRADES FITTED ON THE BACKING PLATE

Testing seal material properties

Testing of seal material is traditionally split into 2 categories: simple wear testing such as pin-on-disc test or testing the complete seal in place on the application. The first method often bears little relevance to the final application and the second is generally too expensive and unsuitable for developing new materials.

Thanks to the flexible choice of specimen materials, surface finish, hardness and coatings, the MTM2 is ideally suited to study the friction and wear properties of seal material.

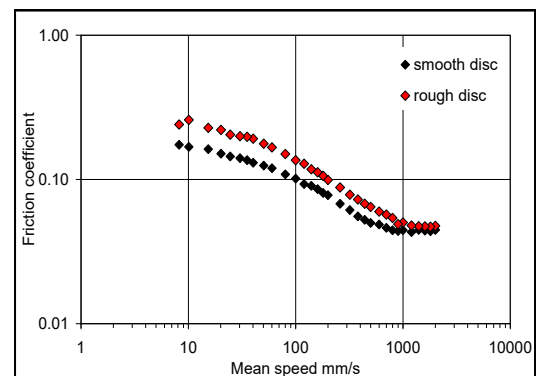

O RING ON STEEL DISC SRR 50%, LOAD 3N,
TEMPERATURE 60°C, MINERAL OIL
INFLUENCE OF COUNTERFACE ROUGHNESS

MTM2 Accessories

PCS has developed a wide range of accessories for the MTM2. Some of these were developed to extend the capabilities of the instrument, such as the grease scoop which maintains grease within the contact during a test. Others were designed to meet the specialised needs of some customers, such as the mini pot and pot filler which greatly reduce the volume of sample fluid required. Some of the more popular accessories are shown below, many more are available to view on our web site.

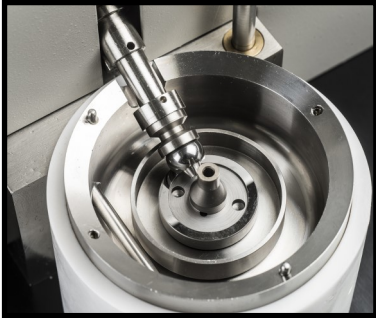

MTM Mini-Pot

Description: Stainless steel mini reservoir replacing the standard disc

Advantage: Reduces sample volume from 35 ml to 4 ml per test. Allows all fluid to remain in the separate pot during the test, reducing cleaning time and allowing for foreign particles (e.g. sand, soot etc. . .) to be examined without needing to replace the disc shaft seal

Limitation: Disc speed limited to maximum 300 mms⁻¹

Supplied Parts: Mini pot, 1/2" ball holder and mini-pot baffle plate

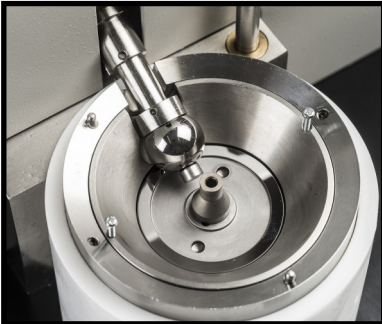

MTM Pot filler

Description: Shaped stainless steel block that fits into the MTM reservoir pot to reduce fluid sample volume

Advantage: Reduces sample volume from 35 ml to less than 10 ml

Supplied Parts: Pot Filler and pot extractor screws



MTM Cooler

Description: Cooler unit and switch box which can be automatically switched on after a test to rapidly cool the pot

Advantage: Speeds up test turn-around and allows testing at temperatures lower than ambient

Supplied Parts: Cooler, silicone cooling oil and PCS software controlled switch box



MTM Grease scoop

Description: PTFE block and spring which guides the grease into the contact

Advantage: Ensures a constant supply of grease through the test

Limitation: Requires modified MTM lid

Supplied Parts: 1 PTFE scoop, 1 spring, 1 positioning rod

MTM Specimen holder for microscope

Description: Holder positions the MTM upper specimen at the correct angle for observation under microscope or surface analyzer

Advantage: Easy to focus on the contact track / wear scar - compatible with 3/4" ball, 1/2" ball, barrel, 3 mm ball

Supplied Parts: 1 holder, 1 screw, 1 barrel adaptor

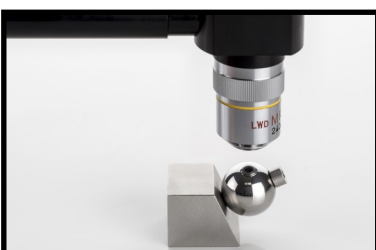

Specimens Selection

Material

The standard disc and ball are made of AISI 52100 steel (760 HV). Other materials are available including AISI 8620 steel, tungsten carbide, aluminium, copper and brass. Contact PCS to discuss alternative material composition or hardness.

Surface finish

The standard specimens are smooth, with a Ra better than 0.01 micron.
Alternative rougher specimens are available with Ra's of 0.15 or 0.3 micron.
Available coatings include pure DLC and Cr doped DLC.



BARREL SPECIMEN FITTED ON MTM SHAFT

Specimen	Usage
3/4" Ball	Standard conventional specimen
1/2" Ball	Small volume testing (4ml per test)
Barrel	Contact pressures up to 3.1 GPa
O-Ring	Test seal materials
Pin	Wear measurement testing - Requires pin-on-disc option
6mm ball	Wear measurement testing - Requires pin-on-disc option



VARIOUS UPPER SPECIMEN OPTIONS FOR THE MTM

MTM2 : Recent Publications

Some recent publications for the MTM are listed below. For more publications on the MTM, please visit our web site www.pcs-instruments.com

'In situ observation of phosphorous and non-phosphorous antiwear films using a mini traction machine with spacer layer image mapping', R. Kapadia, R. Glyde and Y. Wu, Tribology International, (March 2007)

'Grease degradation in a bearing simulation device', P. M. Cann, Tribology International, Volume 39, Issue 12, pp 1698-1706, (December 2006)

'Origins of the friction and wear properties of antiwear additives'. H.A. Spikes Lubrication Science Volume 18, pp 223-230, (2006)

'Friction Reduction and Antiwear Capacity of Engine Oil Blends Containing Zinc Dialkyl Dithiophosphate and Molybdenum-Complex Additives', K. Komvopoulos, S. A. Pernama, E. S. Yamaguchi, P. R. Ryason, Tribology transactions Volume 49, Issue 2, pp 151-165 (July 2006)

'Rolling and sliding friction in compliant, lubricated contact', Vicente J. de, Stokes, J.R. and Spikes, H.A. Proc. I.Mech.E. Part J220, pp 55-63, (2006)

Technical Specification of MTM2 Options

3D-SLIM

Dimensions (H x W x D)

400 x 430 x 200 mm (16 x 17 x 8 in)

Supplied:

RGB camera, optics, light source,
mounting bracket, modified pot lid and software

Reciprocating

Disc frequency

0.1 to 20 Hz for stroke length up to 8mm

0.1 to 12 Hz for stroke length greater than 8mm

Stroke length

4 to 16 mm

Ball speed

-4 to 4 ms⁻¹

Supplied:

Software, mechanical parts

ECR - Electrical contact resistance

Resistance range

10 Ω, 100 Ω, 1 kΩ, 10 kΩ

Supplied:

PCB, slip rings, brushes and software

Cooler

Dimensions (H x W x D)

700 x 600 x 300 mm (27 x 24 x 12 in)

Weight

36 kg (79 lb)

Pin-on-disc

Supplied:

Pin holder, locking screw, locator tool and software



3D-SLIM MOUNTED ON THE MTM2



RECIPROCATING OPTION ACCESSORY KIT

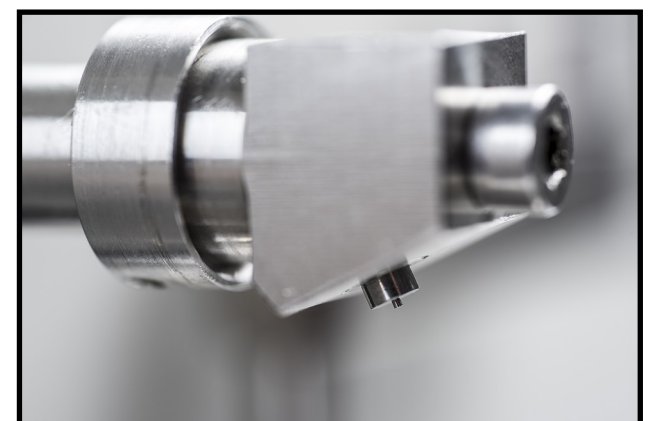

PIN-ON-DISC OPTION

Technical Specification

The MTM2 system comprises a single integrated mechanical and electronic control unit and a PC with data logging software.

Test parameters

Load	0 to 75 N
Contact Pressure	0 to 1.25 GPa (standard specimens) Up to 3.1 GPa with alternative specimens
Speeds	-4 to 4 ms ⁻¹
Temperature Range	Ambient to 150°C (below ambient with optional oil cooler)
Test Sample Volume	35 ml (10 ml with optional pot filler)

Control system

PC	Custom software running on Windows XP/Vista
Safety Checks	Dual platinum RTD's for temperature measurement, safety lock on reservoir cover
Power Supply	100-240V, 50/60 Hz, 750 VA

Dimensions and weight

Weight (Main Unit)	30 kg - 66 lb
--------------------	---------------

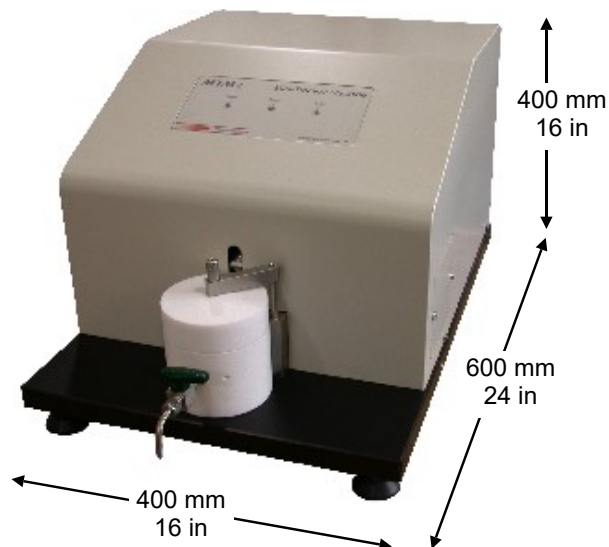

PCS Instruments
LEADERS IN TRIBOLOGY TEST EQUIPMENT

78 Stanley Gardens, London, W3 7SZ UK

T: +44 (0)2086009920

www.pcs-instruments.com